

Review

State of the Art of Urban Smart Vertical Farming Automation System: Advanced Topologies, Issues and Recommendations

Mohamad Hanif Md Saad ¹, Nurul Maisarah Hamdan ¹ and Mahidur R. Sarker ^{1,2,*}

¹ Institute of IR 4.0, Universiti Kebangsaan Malaysia (UKM), Bangi 43600, Selangor, Malaysia; hanifsaad@ukm.edu.my (M.H.M.S.); nmaisarah.hamdan@gmail.com (N.M.H.)

² Industrial Engineering and Automotive, Campus de la Dehesa de la Villa, Nebrija University, Calle Pirineos, 55, 28040 Madrid, Spain

* Correspondence: mahidursarker@ukm.edu.my

Abstract: The global economy is now under threat due to the ongoing domestic and international lockdown for COVID-19. Many have already lost their jobs, and businesses have been unstable in the Corona era. Apart from educational institutions, banks, privately owned institutions, and agriculture, there are signs of economic recession in almost all sectors. The roles of modern technology, the Internet of things, and artificial intelligence are undeniable in helping the world achieve economic prosperity in the post-COVID-19 economic downturn. Food production must increase by 60% by 2050 to meet global food security demands in the face of uncertainty such as the COVID-19 pandemic and a growing population. Given COVID 19's intensity and isolation, improving food production and distribution systems is critical to combating hunger and addressing the double burden of malnutrition. As the world's population is growing day by day, according to an estimation world's population reaches 9.6 billion by 2050, so there is a growing need to modify the agriculture methods, technologies so that maximum crops can be attained and human effort can be reduced. The urban smart vertical farming (USVF) is a solution to secure food production, which can be introduced at any adaptive reuse, retrofit, or new buildings in vertical manners. This paper aims to provide a comprehensive review of the concept of USVF using various techniques to enhance productivity as well as its types, topologies, technologies, control systems, social acceptance, and benefits. This review has focused on numerous issues, challenges, and recommendations in the development of the system, vertical farming management, and modern technologies approach.

Keywords: automation; smart vertical farming; sensors; Internet of Things; urban farming



Citation: Saad, M.H.M.; Hamdan, N.M.; Sarker, M.R. State of the Art of Urban Smart Vertical Farming Automation System: Advanced Topologies, Issues and Recommendations. *Electronics* **2021**, *10*, 1422. <https://doi.org/10.3390/electronics10121422>

Academic Editor: Cheng Siong Chin

Received: 11 May 2021

Accepted: 26 May 2021

Published: 13 June 2021

Publisher's Note: MDPI stays neutral with regard to jurisdictional claims in published maps and institutional affiliations.



Copyright: © 2021 by the authors. Licensee MDPI, Basel, Switzerland. This article is an open access article distributed under the terms and conditions of the Creative Commons Attribution (CC BY) license (<https://creativecommons.org/licenses/by/4.0/>).

1. Introduction

In the 21st century, urbanization will be faster, and the population will reach 6.3 billion by 2050. 67.2% or 6.5 billion of these, are expected to live in urban areas [1]. To feed this growing, increasingly urbanized population, the United Nations estimates food demand needs to rise by 70% [2,3]. Rapid changes in urban built-up areas and skylines in providing buildings and infrastructures to cater to the city center's larger population have altered the urban climate into unhealthy living conditions. This situation threatens the demand for the basic needs of urban dwellers for a livable urban living environment. Furthermore, a larger urban population also demands a fresh and good quality food supply [4]. Urban smart vertical farming (USVF) is one of the potential solutions to help societies meet this elevated demand without additional farmland [5–7]. Figure 1 shows the statistical data about the use of vertical farming (VF) market in the world 2019 and 2025 respectively. In recent years, the global VF market has been increasing steadily as population sizes grow and urban living becomes more common in urban cities. The VF industry reached some \$4.4 billion in 2019, but the market size is estimated to rise to \$15.7 billion by 2025. The opportunity to utilize vertical space and reduce the need for additional land and building

activities adds to vertical agriculture's attractiveness in large cities. Due to the popularity of organic food, VF demand is expected to increase on a large scale [8].

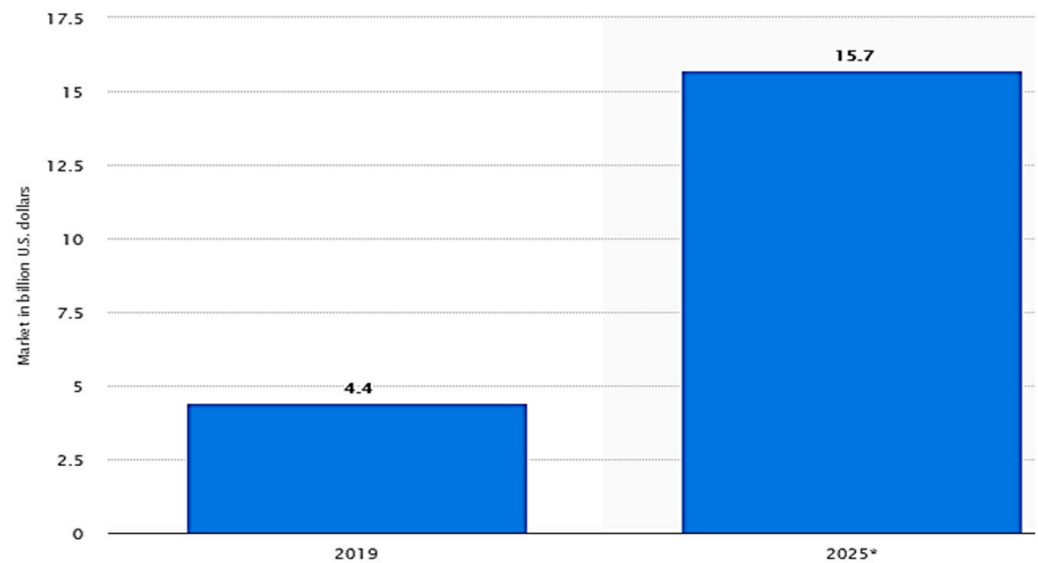

Figure 1. Statistical data about the use of the vertical farming market in the world.

Agriculture is humanity's oldest and most important economic activity, providing us with essential food, fiber, feed, and fuel [9,10]. As the world's population continues to rise while land resources remain constant, there is an increasing need to improve agricultural productivity, which can be achieved by a smart agriculture implementation approach [11–13]. Each crop is unique and has its requirement for growth. The basic requirements for the crops grown are suitable temperature, humidity and soil moisture contents [14,15]. So it becomes a repetitive process for farmers to provide an ideal environment for the crop chosen.

Nowadays, automation plays a vital role in every field of life. Some examples are manufacturing, transportation, agriculture, utilities, defense, facility operation [16,17]. The benefits of automation can be applied in water and wastewater, oil and gas, electric power and telecommunication systems. Automation is generally used in many fields because it reduces human effort, is easy to handle, and is more effective and efficient. By the name of agriculture, farm automation can automate most of the agriculture fields' processes, such as controlling watering systems or flow control and moisture control [18,19]. Similarly, it can build a robot/drone for spraying pesticides and plowing [20]. Harvesting machinery is also used for such purposes: a user-friendly farm automation system, easy user control for a layman, control water, plant health condition, and crop production [21].

In terms of human health, the World Health Organization estimates that more than half of the world's farms still use untreated animal waste as fertilizer, which attracts flies and may contain weed seeds or diseases that can be transmitted to plants. VF has the ability to produce crops throughout the year, with greater control over food safety and biosecurity, while also lowering inputs such as water, pesticides, herbicides, and fertilizers [7]. Food protection is a major concern of our day, as there have been several incidents of events around the world resulting in food recalls due to bacterial infectious diseases, resulting in billion-dollar losses. After the crop has been picked, the washing of field-grown items poses a further risk of infection from various bacteria and pathogens. This stage, on the other hand, has the potential to contaminate the entire manufacturing process [22]. While the whole world is badly affected by COVID-19, the terrible clutches of natural disasters still plague many people worldwide. All scientists' projections show that the number and severity of climate-related disasters are increasing due to climate change, which is cutting off the COVID virus infection and public health response in the wake of the epidemic. The

compound risk arising from the perfect combination of corona and natural disasters has an unprecedented impact on economics. Multiple reports (e.g., global warming of 1.5 °C) have already indicated that one of the features of the 21st century will be deforestation, biodiversity loss, climate chaos, and global epidemics; COVID-19 might be the latest manifestation of this, which has pointed to the horrible meaning of ‘global economy crisis emergency’. Since COVID-19 will have a long-term impact, now is the time to prepare to introduce USVF.

USVF should become an opportunity for urban dwellers to producing their food, despite the limited agricultural land in the city center. Integration of any available potential spaces inside and outside the building by adaptive reuse and retrofit as part of the urban farming (UF) technology should be taken seriously and fully utilized. The design should consider less human intervention in operation due to the hectic life of urbanites. An application of the Internet of things (IoT) can be incorporated into monitoring and controlling in the USVF system [23,24]. Thus, the UF technology can have bigger involvement and contribution of urban dwellers. Besides producing their foods, it contributes to the improvement in a healthy living environment and on urban microclimate. UF offers an once-in-a-lifetime chance to grow food on already built soil, maximize domestic food production, and reduce food travel distances.

This study will include an in-depth examination of the philosophy of USVF as a means of enhancing efficiency, including its forms, topologies, technologies, control structures, social acceptance, and benefits. This review concentrated on a variety of issues, challenges, and recommendations related to the system’s growth, vertical farming management, and modern technology approach. The importance of USVF how it plays a vital role in the economy serve as the starting point for this review. As the world’s population is growing day by day, there is a need to modify those orthodox agriculture methods to fulfill the increasing demand for food. This modification can be done by automating the agriculture farm. This idea of agriculture farm automation wants to control water consumption, the moisture level of soil and water flow, topologies, technologies, control systems, social acceptance and enables an agricultural business to be more productive, efficient and profitable.

2. Types, General Structure and Materials of Vertical Farming

Vertical farming (VF) is a practical technology through which large quantities of food crops and medicinal plants can be produced in a very small space only with the help of advanced technology [25].

2.1. Types of Vertical Farm

VF is practiced in about 13 different ways in the modern world and each way is so technologically advanced that it is enough to revolutionize agriculture [26]. The following section represents a few types of VF utilized for smart UF that are rapidly evolving, diversifying, and improving in the future of agriculture [7].

2.1.1. Hydroponics

Hydroponics is a system that can be called a key part of VF [26,27]. Very slowly, this system has gained popularity. Hydroponics is an approach to developing vegetation barring soil. Instead of having their roots supported and nourished by soil, the plant is often irrigated and supported with the aid of an inert developing medium like cocopeat and is fed through nutrient-rich water that is indispensable to maintain plant growth. Hydroponic structures use 60–70% much less water than regular conventional agriculture [28,29]. In this method, the plant roots are immersed in the mixture of essential nutrients of the plant instead of the soil, in which case the nutrients have to be mixed in the right proportions. Figure 2 shows the structure of the hydroponics VF in Sweden [30]. Hydroponic VF provides many advantages over traditional agriculture, including more productive use of water and soil, and a substantial reduction in transport costs is carried out in urban

areas. However, this paradigm must be intelligently incorporated into current urban infrastructure in order to become economically sustainable.

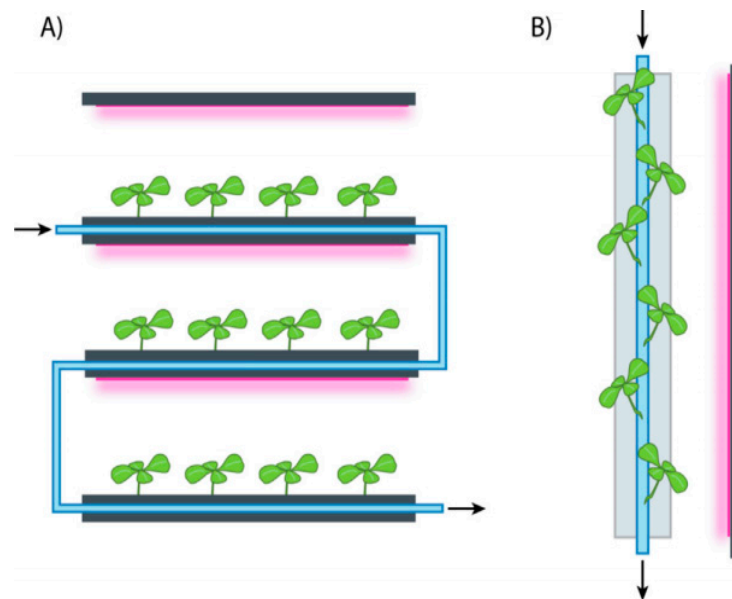

Figure 2. Structure of the hydroponics vertical farm (A) Nutrient film technique. Each tray has LED lighting above it. (B) Drip irrigation system. The column is dripped with nutrient water. This device can either allow for more natural daylight or be illuminated from the side by LEDs. Reprinted with permission from ref. [30]. Copyright 2021 Elsevier.

Hydroponics has the potential to consume more electricity than most greenhouse generation processes. Although hydroponics consume more energy than conventionally grown vegetables and herbs, they consume fewer scarce resources such as water, nutrients, arable land, and pesticides. Hydroponics provides an incentive to grow crops in urban areas, thus creating employment and strengthening the local food supply [31,32]. Operating costs can be reduced by using LEDs with increasing performance, sensor devices that modulate light to the optimum level needed by the plants, combining indoor farms with green energy sources such as solar and geo-thermal, and energy-efficient architectures [33].

2.1.2. Aquaponics

The technology of aquaponics is very similar to that of hydroponics but convenient, in which both plants and fish can be grown in the aquatic environment [34]. In this case, the aquatic ecosystem gets a different dimension that produces plants without soil and shallow water. Aquaponics integrates fish production into the hydroponic developing scheme. More precisely, it makes use of fish waste as a nutrient supply for the plants after treatment, running as a closed-loop ecosystem for indoor farming [28]. Figure 3 shows a schematic diagram of the aquaponics VF [7]. Aquaponic systems offer many advantages, such as faster growth rate, maturity and yields of crops, improved food security and food sovereignty, decreased growing area, reduced water stress in hot weather, and no need for continuous maintenance.

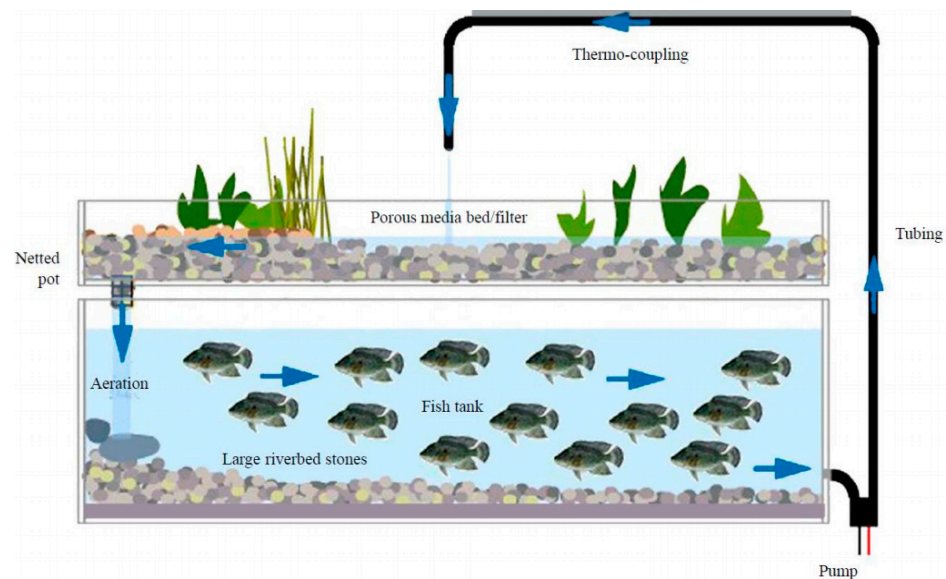

Figure 3. Schematic diagram of the aquaponics vertical farm. Reprinted from ref. [7].

2.1.3. Skygreen

In this way, VF was introduced by a company called Skygreen in Singapore, which brought about a groundbreaking revolution in the field of vertical agriculture [7]. The VF system from Skygreens is made up of rotating tiers of forming troughs connected by an A-shape aluminum frame. The troughs spin around the aluminum frame to ensure that the vegetation receives consistent amounts of daylight, drainage, and nutrients as they pass through the structure's unique features. This is the first ultra-low-carbon hydraulic firm, in which the plants produced on the running shelf continue to rotate throughout the day. In this way, all the plants can get water and light equally [26]. Figure 4 shows a diagram of Skygreen VF technology in Singapore [29]. Skygreen VF technology provides numerous advantages, including the use of green urban technologies to grow healthy, fresh, and tasty vegetables with the least amount of soil, water, and electricity.



Figure 4. Diagram of skygreen vertical farming technology in Singapore. Reprinted with permission from ref. [29]. Copyright 2021 International Journal of Engineering and Techniques.

2.1.4. Skyfarm

London-based buzzers stark harbor, with their partners' help, built a wind-powered VF tower, which they exhibited at the 2014 world agriculture festival [7]. The doctrines of aquaponics and hydroponics were used to some extent in this process. In addition to these processes, there are other methods, such as bowery, zip grows, cubic farming,

modular farms, vertical crop, plant shaper, AeroFarms [35]. Another Skyfarm proposed for downtown Toronto, Canada, is a 59-floor vertical, and the tower embraces the hydroponic technique for developing food, the use of a location totaling about 743,224 m² (8,000,000 ft²). It is estimated that the Skyfarm will produce the equal of a thousand-acre rural farm, feeding about 35,000–50,000 humans per year [7]. Figure 5 shows a concept of vertical Skyfarm technology in London [17]. Vertical Skyfarm technology has a number of advantages, including the ability to produce fresh fruit and vegetables indoors in a city while avoiding the use of fossil fuels for ploughing, planting, and harvesting. Vertical Skyfarms, on the other hand, would reduce air pollution and climate-change-causing carbon dioxide emissions while still creating healthier environments for humans and other species.

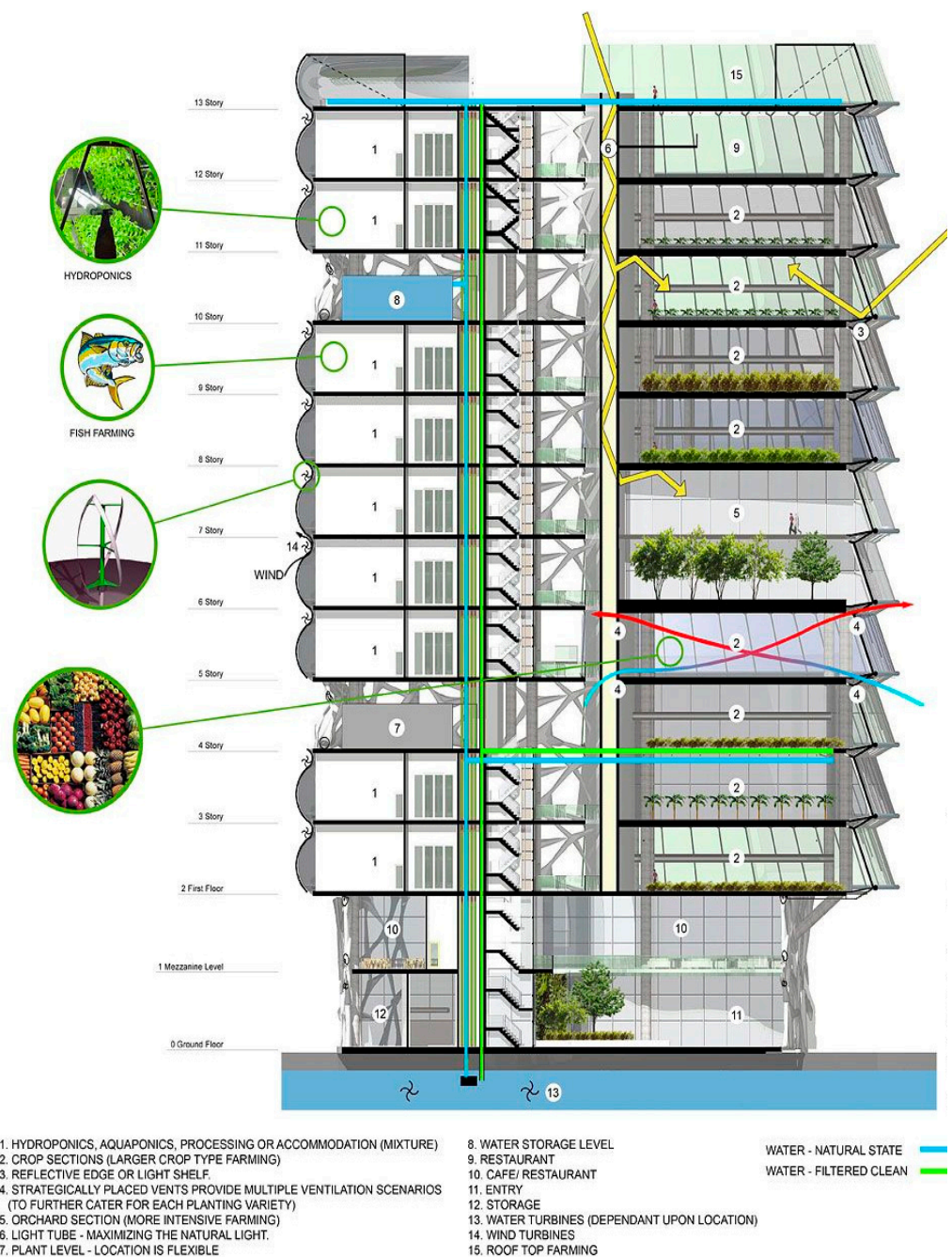

Figure 5. Concept of vertical Skyfarm technology. Reprinted from ref. [17].

2.2. General Structure of Vertical Farm

VF is a type of high-quality UF yield production that comprises bringing manifests in controlled conditions and utilizing soilless development techniques in multi-story structures inside the urban framework [36–40]. The work in [37,40] reported a technique to deal with tending to the future pattern of reducing farming assets, evolving atmosphere, and different elements, including VF's idea. The authors in [38,39] suggested a VF has the efficiency for food production lasting through the year in an air-conditioned competence, reducing carrying expenses, with more prominent control of sanitation and biosecurity, and generously diminished contributions regarding water gracefully, pesticides, herbicides, and composts. In [40], the authors suggested the validity of VF atmosphere reasons which plant development inside the building structures includes less encapsulated energy and deliveries less contamination than some horticultural practices on normal land. The study in [41,42] proposed utilizing high rises buildings to develop food called Skyfarms or yield production factories. The work in [43,44] showed a method is to use a solitary tall glasshouse plan with numerous racks of yields stacked vertically. It is a method of farming initially but different from the other traditional methods. It is an expansion of the greenhouse aquaculture cultivating model and addresses issues identifying with the utilization of soils, for example, the prerequisite for herbicides, pesticides, and manures. Figure 6 shows the structure inner of the USVF.

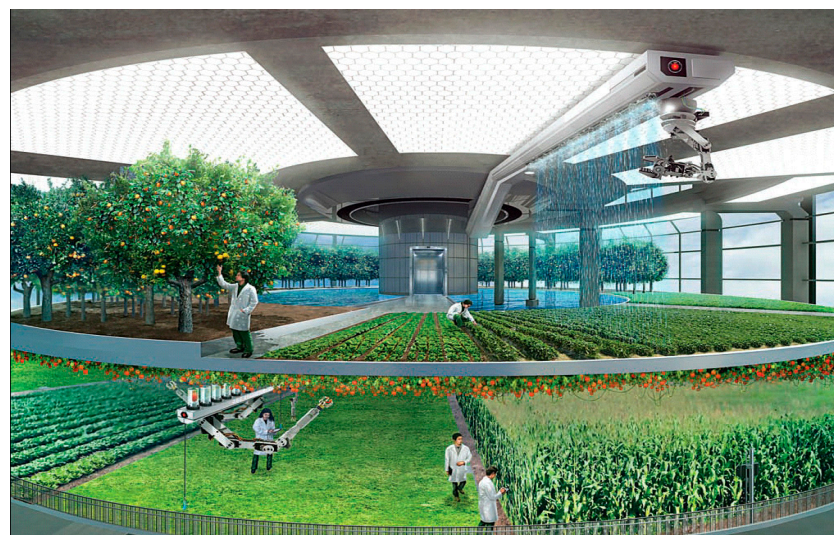

Figure 6. Structure of the inner layout of the urban smart vertical farm. Reprinted with permission from ref. [25]. Copyright 2021 Scientific. Net.

2.3. Material and Components of Vertical Farm

Commercial urban agriculture can be made more sustainable because it can reduce irrigation water waste by 40–60% and increase yields by 3–4 times when hydroponically nutrient-rich water is stored and reused in automatic and climate-controlled buildings [45,46]. Although the use of this technology in indoor VF will be more costly due to the use of artificial materials, the cost will be higher due to the use of local materials. However, in [47], the authors indicated it is also possible to make commercial UF sustainable and profitable by using smart technologies.

2.3.1. Soil

Soil plays a vital element in VF topology in terms of its measurements, quality for each tree. In [48,49], the authors proposed building integrated farming that comprises adjusting soil-less development methods, such as hydroponics. It utilizes on top of such that abuses collaborations between the building and the farming performances. The study reported in [50] presented low-tech alternatives such as rooftop open-air on-soil farming.

The work in [51] addressed a hydroponic agriculture system to manage adequate products to optimize the use of soil that water requires 10.71 m² each day. However, in [51,52], the authors proposed in VF using hydroponics method where no utilizes of soil which widely used in advanced greenhouses worldwide.

2.3.2. Lighting

Lighting plays an important role in making food for a crop in VF [53]. In the VF system, since the trees are one on top of the other, sunlight cannot reach the trees in the middle of the day. However, to solve this problem, the trees should be kept in a place where they get enough sunlight at the beginning of the day and artificial light all time. The conventional light-emitting diode (LED) technologies produce 28% efficiency. However, making an indoor agriculture system cost-effective LED requires more efficiency, at least around 50–60% [54,55]. The work in [55] proposed two techniques LED or high-pressure sodium, to overcome such lighting issues to grow better crops in VF. In [56], the authors indicated the application of LED as greenhouse lighting, and it becomes popular in VF in terms of its lower energy requirements, long lifetime, low cost.

Plants require blue light with a wavelength of 610–720 nm and red light with a wavelength of 400–520 nm. The study in [57], evaluated the use of LEDs in place of natural light to illuminate the plant. The findings indicated that the LED light would assist plants in growing with the used of 3:1 ratio of red and blue LED light to produce a reddish purple color. The perfect color combination for plants and vegetables has been determined to be blue and red. This composition is ideal for promoting rapid plant growth. The combination of 23% blue and 77% red produces optimal plant growth performance [58].

2.3.3. Solar PV

Solar PV is a farming method but different from the other traditional methods such as rooftop VF. It is gaining more popularity in terms of enormous used solar which is available in the urban area [59]. Usually, the crop growth boosts up in the VF by photosynthetic active radiation, and it is not enough Solar power must be collected by a collection of mirrors from the city's structures to reduce the need for supplemental artificial light [60]. As a result, VF is looking for alternatives by looking at solar PV as a source of energy.

2.3.4. Water

In agriculture such as VF, water is used to produce fresh crops. The use of agricultural water makes it possible to produce crops, vegetables. The study in [61] addressed a VF technology that requires 70% less water and the amount of water required is also recyclable. Historically, users of traditional agricultural systems were expected to manually check the water level in their water tanks. Moreover, uncontrolled water use leads to wastage of water, which ultimately causes water scarcity to terminate. In [25], the author indicated that showers and washing hand water could be used by filtered other than rainwater in the smart VF system, which may help optimize water use. In [61,62], the authors indicated through the geponics method, water utilizes less than 70% in VF, while the hydroponics technique still using 70% water. Water automation systems can be used in VF technologies to reduce human effort and error. Additionally, users can use an Android program to turn on and off the water pump. This is an effective and cost-effective method of minimizing water waste and human labor. Additionally, [62] addressed an integrated device built on an Android application that controls and tests the water pump and water level in smart farming (SF).

3. Technologies in Smart Vertical Farming

VF is a state-of-the-art technology that has given an open scope to modern farming in a rural environment and range [25,63]. The aim of this study, sincerity towards USVF and the use of technology, have invented this new type of agricultural thinking. The

agriculture industry could be further developed by employing new technologies in the era of modernization.

3.1. Sensors Technology in USVF

The agriculture field in the world is progressing day by day. For six decades, automation played a vital role in industries to increase their productivity and decrease their expenses. In the last two decades, agriculture has begun to follow a parallel pattern, using GPS and sensor-based devices [21,64,65]. Agriculture sensors are the sensors used in smart VF. These sensors provide farmers with data that enables them to track and optimize crops in response to changing environmental circumstances [66]. These sensors are integrated into weather stations, drones, and robots used in the agriculture industry [67]. To realize VF, technology makes extensive use of sensors and actuators (dubbed smart equipment) that communicate with other devices autonomously. This section provides a detailed discussion about sensor types and uses in VF applications. Figure 7 shows the block diagram of simple sensors and smart sensors.

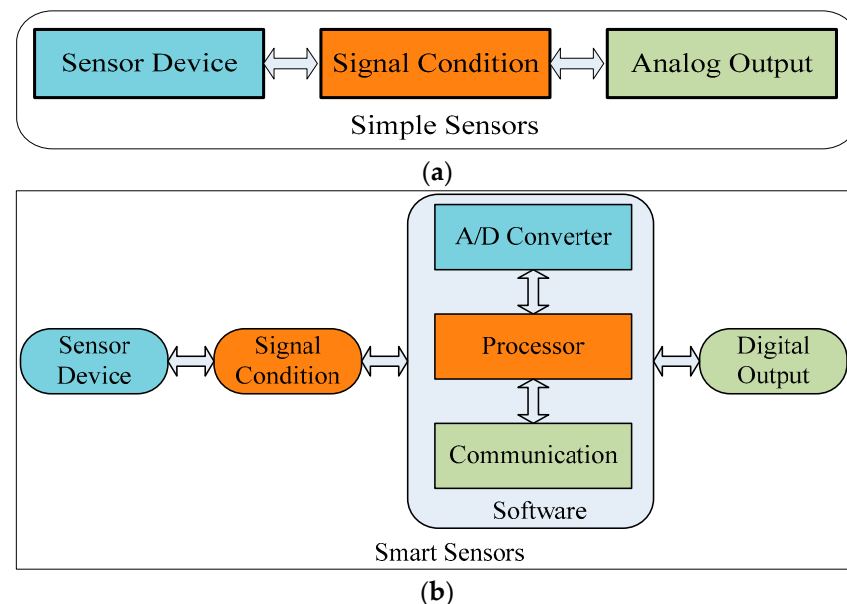

Figure 7. Block diagram of the simple sensors (a) and smart sensors (b).

3.2. Sensors and Actuators Type in Smart Vertical Farm

SF is the key to developing sustainable agriculture. As a result, USVF is a cutting-edge agricultural technology that significantly increases the yield obtained from traditional agriculture. The USVF is moving toward becoming a quickly developing farming system in the future. Additionally, the SF system entails integrating information and communication technology into agricultural machines, vehicles, and sensors. A sensor is a system that detects and transmits an impulse in response to a physical stimulus such as heat, illumination, sound, vibration, magnetism, or a specific motion. By the name of VF automation system using different types of sensors, it can automate most of VF processes, such as we can control watering system or flow control, the moisture level of soil, crops health [68]. However, existing agriculture technology faces challenges in growing crops due to various issues, such as unstable environmental situation, limitation of more food, safety, reliability, cost, life cycle, and overall management [69–71]. Therefore, advanced USVF technology sensors generally used to reduce human effort, easy to handle, more effective and more efficient. Figure 8 shows the sensors and actuators types which utilize in SF. Sensors and actuators are used in SF to provide autonomous services. Sensors are directly connected to environmental parameters to capture data of interest, such as shifts in natural light and information about the increasing environment, such as temperature and ph. a The actuators

are by implication connected to the parameter. The actuator regulates the operation of the control equipment, which includes a ventilation fan, an air cooler, a refrigerator, a pressure pump, a humidifier, and a lamp. The effect of the actuator’s interaction with a number of environmental parameters influences the actuator’s ability to maintain an optimum condition by regulating the machinery [72].

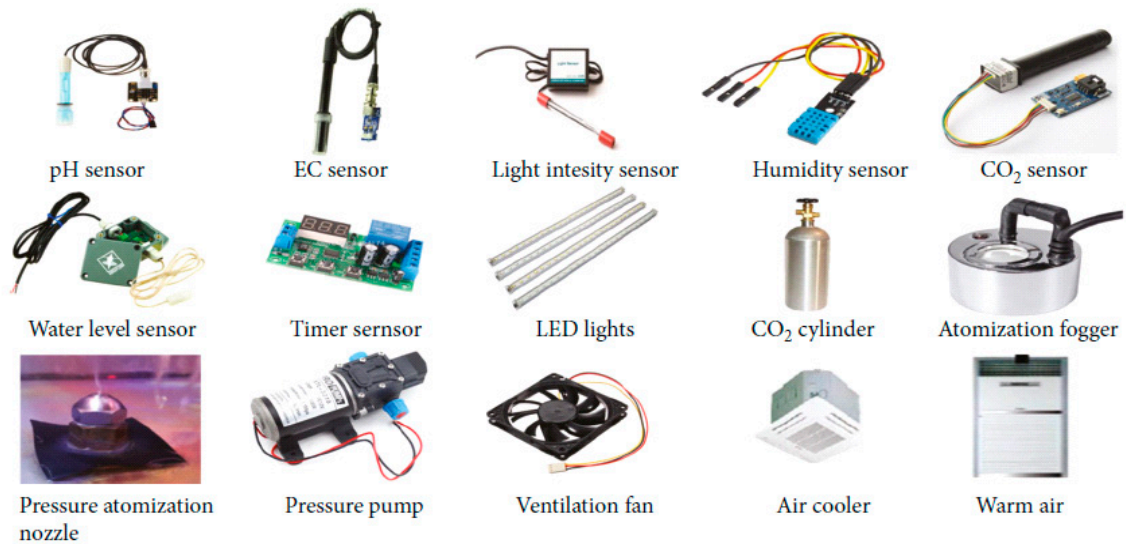

Figure 8. Sensors and actuators types utilized in the smart farming. Reprinted from ref. [21].

Soil Sensor in Agriculture

Currently, sensor technology plays an important role in USVF. Soil sensors have become more compact, durable, fast, reliable, energy-efficient, wireless, and intelligent [73,74]. Figure 9 shows a block diagram of soil and plant sensors in USVF.

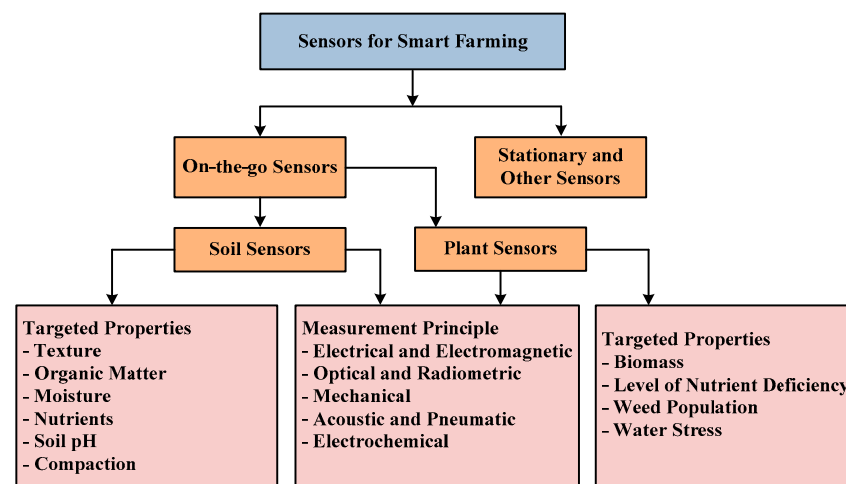

Figure 9. Soil and plant sensors used in smart framing.

Texture Sensor

In agriculture, the texture sensor is used to determine the soil surface, bulk density (compaction), and variability in soil depth (depth of topsoil, depth to hardpan). The study in [75] reported various technical types of equipment available for on-farm used to measure soil electrical conductivity and soil texture. In [76], the authors indicated most soil texture sensors provide only indirect data on soil status and soil electrical conductivity.

Sensor for Organic Matter

Organic matter is the portion of soil that is composed of plant and animal residues at different stages of decomposition, soil organism cells and tissues, and substances synthesized by soil species. The work in [77] suggested that soil organic matter sensors could be used to track a variety of beneficial effects on the physical and chemical properties of the soil, as well as the soil's capacity to provide regulatory ecosystem services. The existence of soil organic matter sensors, in particular, is regarded as important for soil functions and consistency. The study in [78], soil organic matter sensors track soil functioning, including changes in soil composition, accumulation, water preservation, soil fertility, pollutant absorption and retention, buffering capability, and nutrient cycling with storage. In [79], the authors state that soil organic matter sensors used to select sustainable soil to produce urban VF crops.

Moisture Sensor

The device used to measure soil moisture or any other media is known as a moisture sensor [80]. Mostly, the humidity sensor and the moisture sensor are the same, but they are different in the sense that humidity sensor measures water content in the atmosphere or our surroundings, but moisture sensor measures the water content in a specific medium such as soil, sponges [81]. Therefore, it is perfect for build an automatic watering system or monitor the soil moisture of smart VF. For measuring moisture of content, there are two methods as shown in Figure 10.

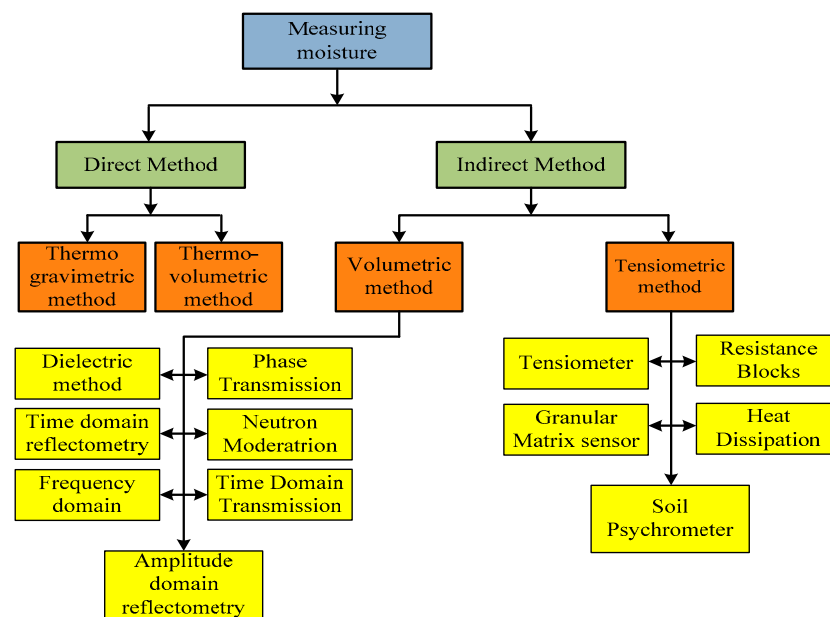

Figure 10. Methods of moisture sensors.

The indirect method is a technique used to measure soil moisture. In this technique, we estimate the soil moisture by a calibrated relationship by some other measurable variables such as current and resistance [82]. These methods are less accurate than the direct method but are less time-consuming. Their suitability depends on several parameters such as cost, accuracy, installation durability [83]. This volumetric method measures the volume of the water content in the soil. It can be used to measure the soil saturation (i.e., the fraction of the total volume of the soil which is filled with the soil aqueous solution). It can be used to determine the relationship of moisture at depth to the moisture at the unit surface area. This method is also comparable with other parameters such as precipitation, deep drainage, and transpiration.

pH Sensor

A pH sensor is an electronic device that utilizes to measure acidity, power of hydrogen value, and alkalinity of substances. The use of pH sensors plays a vital role in the industry, agriculture, manufacturing, pharmaceutical, etc. [21,84,85]. In [84,86], the authors indicated using a pH sensor to find the nutrient level of agriculture soil that connects to the Arduino microcontroller, reducing fertilizers used in smart agriculture. The authors also addressed pH sensors to collect and monitor real data from different soil of SF, which save to cloud server. However, the unnecessary growth of the plant in the agriculture farm does not grow well for crops. Therefore, to overcome such a problem, pH sensor plays a vital role in SF.

Sensor of Electrical Conductivity

The electrical conductivity sensor is largely used in SF to measure the soil solute concentration [87,88]. However, there are still some limitations to use it properly in the SF. In [88], the authors addressed the soil contains some water and salt that harmful to grow up crops, which can measure using an electrical conductivity sensor based on Faraday's law. The study in [89] showed an electrical conductivity sensor used to overcome soil limitations, such as measuring soil pore water, reducing cost and saving working time.

Temperature Sensor

Usually, temperature sensors are used to measure soil temperature in the farm plant [90,91]. The work in [90] indicated the importance of plant growth based on temperature control processes such as photosynthesis, transpiration, absorption. In [92], the authors proposed an aeroponic system in agriculture, which indicated plant growth and development through temperature. Therefore, the temperature sensor plays an important role to measure soil temperature, which increases the efficiency of plant growth and more crops.

Electromagnetic Sensor

Electromagnetic sensors calculate the potential of soil particles to conduct or produce electrical charge using electric circuits [73,93]. As these sensors are used, the soil is now an electromagnetic loop, and any changes in local conditions have an instant impact on the output captured by a data acquisition system. In [93], the authors indicated electromagnetic sensors for soil measure have become smaller, more rugged, faster, more accurate, more energy-efficient, wireless, and smarter.

3.3. Smartphone Sensor Technologies in Smart Farming

Telecommunications advances are allowing the rapid and more reliable delivery of sensed data on a global scale. A sensor is a device that detects and reacts to an electrical signal. Traditional phone sensing systems need additional infrastructure, which is unaffordable to the majority of consumers. Smartphones have advanced at a breakneck pace in recent years, and they have evolved into an integral part of everyday life. The sensors embedded in them allow a variety of mobile application, which are assisting and transforming our way of life. Mobile sensors technology can enhance UF by improving connectivity, increasing the flow of information, ensuring traceability for large buyers, and creating economic opportunities [94,95]. This section illustrates concepts of mobile sensors technology in SF that are currently using in the smartphone and comparison among several research outcomes.

Sensors are a tool that measures a physical amount and converts to a signal which can be read and utilized by other devices. Most of the mobile sensors are equipped on smartphones. Numerous forms of sensors are available nowadays, and several common smartphones include accelerometers, GPS, illumination sensors, temperature sensors, gyroscope, and barometer. These sensors evolved into a high-quality database for tracking many facets of a user's everyday activities. Three types of sensors are installed in smart-

phones: motion sensors, ambient sensors, and location sensors [94]. The following Table 1 summarizes and illustrates a set of popular sensors found in today's mainstream smartphones. The first category, motion sensors such as accelerometers, gyroscopes, gravity sensors, and rotational vector sensors, provides acceleration force and rotational force measurements. Environmental sensors, on the other hand, provide observations of the ambient environment. This includes measuring the ambient air temperature with a thermometer and the atmospheric pressure with a barometer, as well as lighting with a photometer. Place sensors, on the other hand, provide information about the physical location of the system. Magnetometers, GPS, and orientation sensors are examples of location sensors [94].

Table 1. Familiar smartphone sensors. Reprinted from ref. [94].

Sensor/Detector	Explanation	Usage
Accelerometer	Measures the acceleration force in m/s^2 that applies to every one of the three bodily axes (x , y , and z) including gravity of a device.	Recognizes movement and senses the progressions in smartphones' direction.
Ambient temperature sensor	Measures the encompassing room condition in degrees Celsius ($^{\circ}C$).	Monitors air temperatures.
Gyroscope	Measures a device's rate of revolution in rad/s around every one of the three physical axes (x , y , and z).	Recognizes rotation (spin, turn, etc.)
Light sensor	Measures the number of ambient light levels (illumination) in lux.	Manages screen brightness.
Magnetometer	The surrounding geomagnetic field is measured in μT for all three physical axes (x , y , and z).	Generates a compass.
Barometer	Measures the ambient air pressure in hPa or mbar.	Detects air pressure variation.
Proximity sensor	Measures the distance between an object and the device's display screen in cm.	Identifies if the phone is being put up to a person's ear amid a call.
Humidity sensor	Measures the humidity of the surrounding environment in percentage (%).	Supervises dew-point, absolute, and relative ambient humidity.
Global Positioning System (GPS)	Measures the latitude and longitude of the current place or area of the gadget.	Employments a user's area to appear the adjacent information.
Image sensor (camera)	Records pictures and videos.	Taking still photos or videos.
Audio sensor (microphone)	Measures sound in air into an electrical indicator.	Records voices.
Fingerprint identity sensor	Reads a user's unique finger impression.	Recognizes a user through touching.
Moisture sensor	Distinguishes whether the device has been submerged in water.	Identifies if a device has internal water damage and can warn the user.

3.3.1. Accelerometer Sensor

Accelerometer sensors are largely used in the SF to predict and assist with necessary maintenance [96,97]. The study reported in [96] presented accelerometer sensor plays an important role in monitoring the conventional use of equipment in the SF. In [98], the authors indicated accelerometer sensors detect running components or motor's health conditions through motion, speed, vibration inconsistencies. Therefore, users can easily track the component health condition using an android application in SF.

3.3.2. Gyroscope Sensor

A gyroscope is a system that uses the theory of conservation of angular momentum to determine or retain orientation. Nowadays, gyroscope sensors are used in a variety of areas, including science fiction and mobile devices [94,99]. In [94], the authors indicated a gyroscope sensors application to detect conventional equipment rotation in SF using an android phone. However, the drawback of this gyroscope sensors application in smart VF

difficult to implement in terms of requiring a complex mathematical model to conduct a signal.

3.3.3. Light Sensor

The term “smart agriculture techniques” refers to the practice of using a sensor system to regulate the amount of light available [100,101]. The light sensor is a semiconductor chip that detects the presence or absence of light and darkness. Photoresistors, photodiodes, and phototransistors are all examples of light sensors. The study in [100] proposed artificial lighting as a suitable option to confirm most of the time availability of light for the healthy plant in smart agriculture. However, the drawback of artificial lighting in the SF fault finds out and unnecessary light in the daytime. Therefore, to detect the fault and On/OFF artificial light system in the smart farm using an android phone application which reduces the human effort and optimize cost [102].

3.3.4. Magnetometer Sensor

Basically, magnetometer sensors are used in SF to measure the direction of the workers, such as walk forwards, walk backward, run, harvest fruit. The advantages of using the sensors by mobile phone which help farmers with decision-making, enabling them to have a deeper, richer knowledge about their farms [94].

3.3.5. Proximity Sensor

The proximity sensors utilize to monitor crop flow during collection data in VF [94]. In [71], the authors usually indicated crop plant temperature control from a heat source measured by a proximity sensor in SF. The study in [94,103] reported proximity sensors are utilized to measure grain yield in the agriculture farm, which helps to reduce human effort, measure accurate crop, save time, and can work in harsh environmental conditions. However, proximity sensors’ drawbacks can detect only the metallic target, and the operation range also limited.

3.3.6. Humidity Sensor

Nowadays, the demand for humidity sensors is gaining popularity in SF [104,105]. The work in [105] addressed humidity sensors play an important role in SF, such as tracking the water level of plants, environmental monitoring, which suitable time for proper crop selection. The authors also indicated the humidity sensors are steady and flexible at measure bio-interface. Nevertheless, challenges still occur for the awareness of capable and wide-scale manufacture of adjustable humidity sensors for bio-interface applications. In [106], the authors indicated humidity sensors increase their demand in agriculture farming by controlling the humidity created by porous materials, namely metal-organic structure due to their large porosity and tunable shape. However, the drawback of this metal-organic structure is its response time is high and displays a narrow sensing range.

3.3.7. Carbon-Based Sensor

The carbon-based sensor has many benefits as opposed to other types of sensors. The carbon-based structures used in sensor applications are carbon nanotube (CNT), nanodiamond (ND), fullerene (FLN) and graphene (GPN). Due to their superior electrical, thermal, mechanical, and chemical properties, nanodiamonds, fullerenes, graphenes, nanotubes, and hybrid structures have been widely used. Carbon nanostructures, as described in [107], exhibit a high degree of selectivity, especially when functionalized. Carbon nanostructures have grown in popularity as gas sensor applications due to their promising structure, which enables gas detection and quantification. The high surface-to-volume ratio and hollow composition make this material suitable for gas adsorption and desorption. The identification and quantification of polluting gases, especially hydrogen sulfide (H₂S), carbon monoxide (CO), carbon dioxide (CO₂), nitrogen oxide (NO_x), ammonia (NH₃), and methane, is one of the primary applications of carbonaceous materials as gas sensors (CH₄).

The special properties of nanomaterials, such as their compact scale, large surface area, and reactivity, make them ideal for use in agriculture. CNTs (carbon nanotubes) are primarily used in agriculture for germination rate, initial crop production, pesticides, and biosensor diagnostic tools and evaluation [108]. Nanotechnology is important in the purification of water. Carbon nanotubes can be used to purify wastewater [109,110]. Adsorption and degradation/detoxification are the primary strategies for removing contaminants from samples using carbon nanotubes. Additionally, not only is it necessary to remove toxins from various environmental compartments, but it is also necessary to control pollution levels. Carbon-based nanomaterials can be used to create novel, highly effective biochemical sensors for the detection of chemical compounds at extremely low concentrations in a variety of environments. In [111], the authors stated that carbon-based nanomaterials will account for 40% of all nanotechnology contributions to agriculture, both as additives and active parts. The bulk of these implementations are currently in their infancy, and this section will highlight some interesting methods.

3.4. Sensors Technology in Farming to Monitoring of the Healthy Growth of Crops

The proper growth of plants is important to enhance the quality of the crop in the smart VF. The economic and benefit depend on the proper healthy growth of the plant. However, there are some essential elements that are required for the growth of plants, such as crop life, nutrients, crops health condition, and micronutrients [112,113]. Therefore, monitoring the health condition of each plant of agriculture farming is essential [114]. Therefore, different types of sensors utilize to overcome such issues in smart VF. Table 2 shows the summary of the method used for crop health growth monitoring using a different type of camera model sensors in SF. This list consists of various types, brands, model numbers and application in SF. The sensor application in SF includes counting faster crop damage accuracy, monitoring and detecting defect crop growth, and diagnosing the nitrogen of crop and tracking leaf damage from the insect.

Table 2. Review of methods and sensors used to monitor crop growth.

Reference	Application Objectives and Outlines	Type of Sensors	The Outcomes Obtained	Advantages and Disadvantages
[115]	Measurement of plant morphology and parameters.	Canon PowerShot SX20	Chlorophyll content parameters of plants were obtained.	Strong versatility, low cost and relatively simple.
[116]	Detection and quantification of plant growth indicators, etc.	-A camera mounted to Bonirob. -Canon PowerShot S95. -Canon EOS REBEL T2i	A very significant result was achieved.	Capability of working with a diverse range of crops and ecosystems Analyzing images of backlight remains challenging.
[117]	Monitoring of grape growth.	Visible spectrum cameras.	Grape bunches and individual berries were observed with a high degree of accuracy.	It performs consistently in a variety of lighting and occlusion conditions.
[118]	Monitoring of palm oil plantations.	DJI Drone Phantom 3 Standard.	The system's precision was reached.	Information can be obtained more easily and reliably using UAV-based control.
[119]	Nitrogen determination in rice leaves.	A high-resolution camera.	The mechanism of blade transition was quantified.	Without risking harm, continuous and complex analysis can be done.
[120]	Inspection of the wheat heading date.	E450 Olympus	In comparison to other methods, the method's absolute error is 1.14 days.	The approach has a low error rate and a high degree of robustness.
[121]	Identifying the growth stage of the plant during the heading and flowering phases.	8 MP camera	The flowering detection accuracy is 85.45%.	Heading and flowering can be tracked concurrently with a high degree of detection precision and robustness.

Table 2. Cont.

Reference	Application Objectives and Outlines	Type of Sensors	The Outcomes Obtained	Advantages and Disadvantages
[122]	Aphid detection and count on soybean.	-Canon EOS Rebel T2i -Sony DSC-W80 -Panasonic DMC-ZS20 -Canon EOS Rebel T2i DSLR -Canon power shot G11.	Mites can be identified and counted using the image processing toolbox.	Reduced cost and optimal precision in low light. However, there are several distinctions when working in low light.
[123]	Popular invertebrate pests discovered in farmland.	Foral reflectance database.	Acceptable accuracy	Precision is excellent, and the robot system's performance can be improved in real time.
[124]	Fast counting and identification of flying insects.	Raspberry Pi Camera Module v2	Average counting accuracy is 92.50% and the overall accuracy of classification is 90.18%.	It is possible to conduct easy-to-use, real-time intelligent surveillance.
[125]	Stripe rust spores are automatically counted.	An inverted microscope.	The accuracy rate is over 95%.	Though accuracy is good, additional research in natural and non-natural environments is needed.
[126]	Sweet pepper crops accurately identified.	JAI AD-130GE.	Ideal identification is accomplished by the use of the LBP feature.	Though these features are novel and similar to the impact of the human eye, the accuracy also needs to be enhanced.
[127]	Automated harvesting of apples.	Prosilica GC1290C Camcube 3.0.	The selection rate is 95%, and the average time required for positioning and picking is 1.2 and 6.8 s, respectively.	Low cost and high efficiency
[128]	Damage to sweet lemons can be detected quickly and non destructively.	Canon powershot-SX30 IS.	The approach is 100% accurate for both damaged and undamaged fruits.	The accuracy of quality detection and classification is very high.
[129]	Nondestructive testing of potatoes.	Monochrome CCD camera.	Achieved a higher Accuracy.	Non-destructive, high-precision.
[130]	Blueberry internal injury detection.	Isuzu Optics Corp., Taiwan.	The results demonstrate that the two deep learning models outperform conventional classification approaches.	Combining a CNN structure with hyperspectral transmittance data enables enormous growth opportunities.
[131]	Detect tomato maturity.	SONY NEX5N.	The system for determining tomato maturity has an overall accuracy of 99.31%.	Outstanding accuracy and a high level of satisfaction.
[132]	Estimation of citrus crop yield.	SONY DSC-W530	The false positive rate is 3% in photographs acquired under ideal conditions.	High efficiency and small error
[133]	Estimation of corn biomass.	-Quadrotor UAV-RGB -remote sensing system -DJI Phantom 4 Pro	The effect is ideal.	It is compatible with machine learning.
[134,135]	Monitoring sugarcane field.	-eBee Ag with a Canon -PowerShot S110 compact camera	OBIA is highly automated and adaptable.	It will aid in decision-making and agricultural surveillance.
[136]	Improving irrigation accuracy.	Phantom 4 Pro drone with an integrated camera.	The area's irrigation accuracy improved from 71% to 95%.	It possesses a certain degree of viability and applicability.

In [115,128] authors proposed Canon PowerShot SX20 and Canon PowerShot SX30 sensors in farming applications because of cheap, easy to manage, and potential versatility to count faster crop damage accuracy. The study in [116,122] reported a Canon EOS REBEL T2i and Sony DSC-W80 sensors in agriculture application used to monitor and detect crop growth. However, these sensors' drawback is that image quality is still inferior and not performing well in low light. On the other hand, its advantage performs well in a suitable lighting atmosphere and low cost. In [117,121], the authors reported visible spectrum cameras and 8 MP camera sensors to measure the early stages of crops grown in SF applications. The merit of such sensors might work in various lighting environments with strong controlling efficiency and robustness. Therefore, it is suitable for VF applications. The study reported in [119,124] proposed high-resolution and Raspberry Pi camera sensors in agriculture applications to diagnose the nitrogen of crops and track leaf damage from insects. It is suitable in VF terms of its longevity, fast counting capability, and continuous act without damage. The study in [120,123] addressed E450 Olympus and floral reflectance sensors in agriculture application to observation insects on each leaf and plant growth. The sensors gain popularity in terms of simple to use, deliver robust real data in a short time, and strong controlling capability. In [125,137], the authors reported an inverted microscope and plant village sensors in SF application to automatically monitor health conditions in plants, which is easy to implement, no need complex mathematical model. The authors in [138–140] reported DFK 23GM021, Hyper HAD CCD, and Logitech digital webcam sensors in agriculture application to monitor selecting crops in a greenhouse environment and various weeds automatically. However, those sensors' limitation is the accuracy required to be enhanced in terms of data delivery time, efficiency, and cost. Therefore, to overcome these issues optimization techniques can be utilized.

The study in [126,141] reported 0.9R-G and JAI AD-130GE sensors in agriculture application for proper identification of crops cherries and sweet pepper automatically in the USVF. However, the challenges are its complexity, cost, and overall efficiency still very poor. In [127,142,143], the authors proposed a camcube 3.0, UniflyM216, and MV-VDM033SM/SC sensors in agriculture application to harvest the crops such as apple, carrot automatically by a robot in SF. The approach has high efficiency, low cost, and high precision for the overall system compared to conventional methods. However, the main limitations are its monitoring accuracy, such as nighttime, tracking the exact position of crops. In [129,131,132], the authors proposed Monochrome CCD, SONY NEX5N, and SONY DSC-W530 sensors in agriculture applications to detect crop growth such as tomato, potatoes. Therefore, the main advantages of such sensors in USVF overall efficiency, large accuracy, low error, and easy maintenance. In [133,144,145], the authors proposed an unmanned aerial vehicle (UAV) with geolocation, a UAV platform equipped, quadrotor UAV-RGB, senseFly eBee with RGB and CIR sensors in agriculture application to detect height, biomass automatically of crop plants. Therefore, the main advantage of such sensors in SF is that they are stable, perform well, have small defects, are easy to adapt to new technology, and they have a simple operation.

Figure 11 shows the smartphone applications in agriculture and the camera model sensors used in VF. The smartphone application for farming, such as data gathering, farming calculator and news and weather information was included to monitor and enhance the quality of the crop in the smart VF. The added camera model sensor technology in farming used to monitor the healthy growth of crops such as E450 Olympus and Canon PowerShot SX20 counts faster crop damage accuracy and observes insects on each leaf.

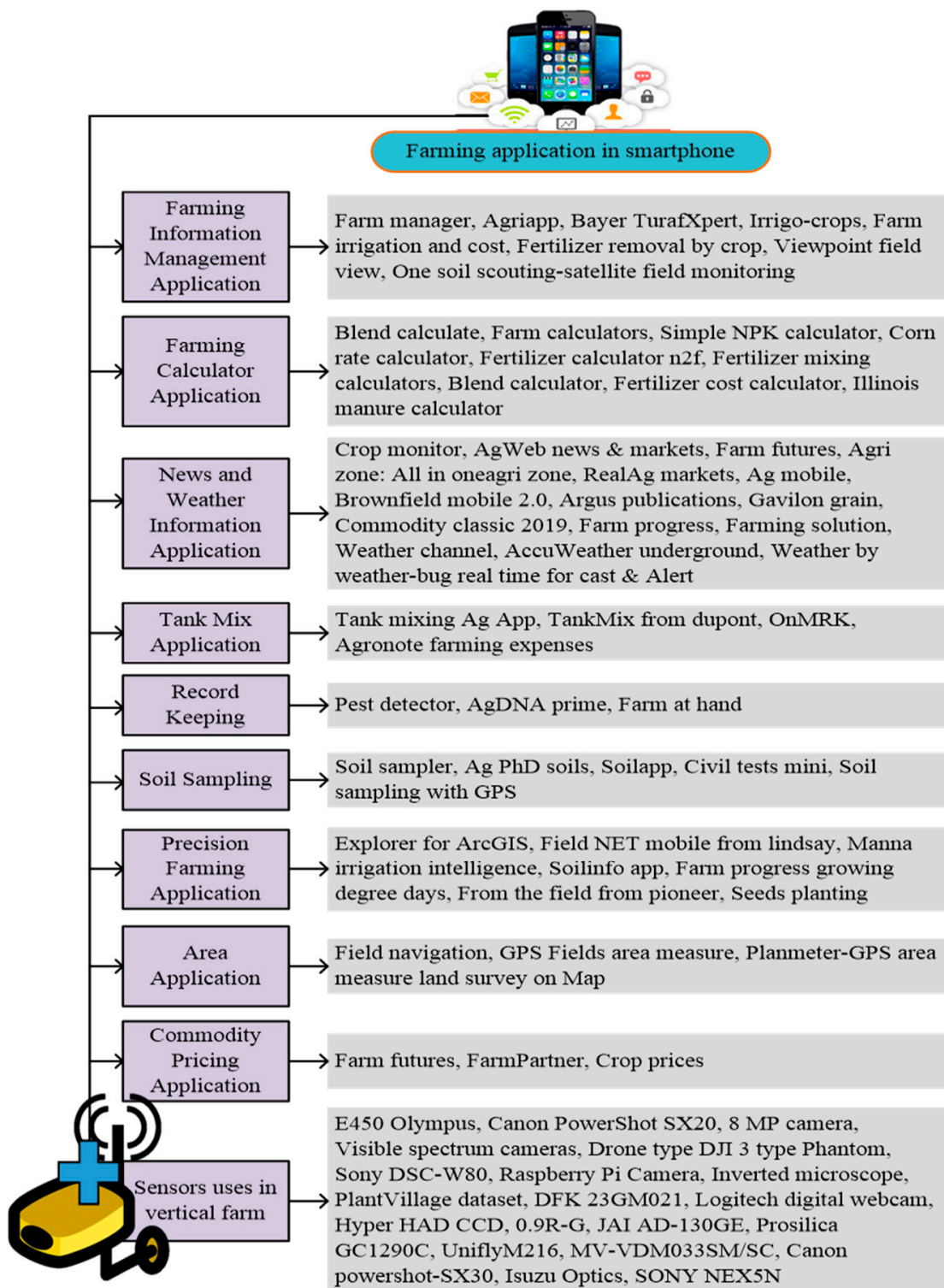

Figure 11. Smartphone applications and the camera model sensors for smart farming.

4. IoT Framework on Smart Farming

With the development of technology and knowledge-science, human thought-consciousness is developing. As a result, everything is changing. The revolutionary development of life and human thought in the world over the last few decades is far more exemplary than the changes in the previous few centuries. The transformation of the agricultural sector, like all other sectors, is much more pronounced. Information-driven

advances, when all is said in done, are rapidly progressing with the improvement of the IoT and may turn into a significant piece of things to come of farming [146–148]. All modern methods are now being followed to ensure more production on less land to meet the needs of the age, for example, IoT technology in USVF. In [149–151], the authors proposed an IoT a very modern technology in SF in which farmers can find out problems of yield, such as lacking water, crop productivity, yield weakness, and also provide quick solutions to such issues. In the study [152,153], authors reported a producing efficient yield controlling the atmosphere situation, soil preparation, crop monitoring by IoT. The study also indicated IoT delivers real-time sensing data which aids in efficient crop production.

Figure 12 shows details IoT based SF structure. The IoT-based SF framework consists of six interconnected sub-systems: a physical layer, network layer, middleware layer, service layer, analytics layer, and user experience layer [154–156]. The physical layer of SF is consists of various types of components such as sensors, actuators, controllers, switches, network gateways, routers, etc. The controller is an essential part of this layer which plays an important role in SF to connect network-related functionalities as well as other operations of sensors and actuators. The main feature of the network layer is capable of transferring root-level data from sensors which use different purpose in VF. The network layer is a vital technical layer for smart cultivating, which is important for sending specific information, network connectivity to the application layer. The network layer incorporates various types of wired and remote interfaces for associating the weeding machine, food harvester, and for correspondence of machines and sensors with cloud frameworks. However, the challenge of the network layer in SF where IoT generated a huge amount of data is not only the reason for storage or maintenance but also the reduction of network efficiency [157,158]. The middleware layer assumes an essential function to boost IoT security in SF. In [159,160], the authors indicated an IoT-based middleware acts as device controlling, setting management, sensation, platform ability, and surveillance relevant tasks. Middleware remains in the middle of the utilization layer and network layer which are capable of handling information and gives a combination for connection between these layers. However, the middleware layer includes safe and sensitive data storage, and data transfer over wireless is extremely difficult in IoT deployments. IoT cloud support service layer assumes a vital part in giving distributed storage, Software-as-a-Service (SaaS) to farming issues. Sensor information procurement, materials recognition, crop health condition data monitoring, factual investigation administrations are cleared to encourage the detecting, activating, and infection recognition operation [21,68,161]. The analytics layer's aim is to ensure big data processing for crop production investigation yield efficiency based on environment condition. Another sensor-based IoT system for the analytics layer was presented in [162], which ensures crop implement fragmentation, compression, and a reassembly mechanism. However, the main drawback of the analytics layer in SF since its direct use on IoT devices is not viewed as sensible [149,163,164]. The user experience layer is developed to aid the purpose of farmer yield productivity, such as crop growth condition, efficiency, soil quality, and environmental situation. IoT plays a vital role to monitor, control, and deliver to farmers an overall situation of VF yield condition by different sensors. However, the main challenges still most of the IoT sensors power by the battery. Therefore, to overcome these issues, energy harvesting technology can be utilized to replace batteries.

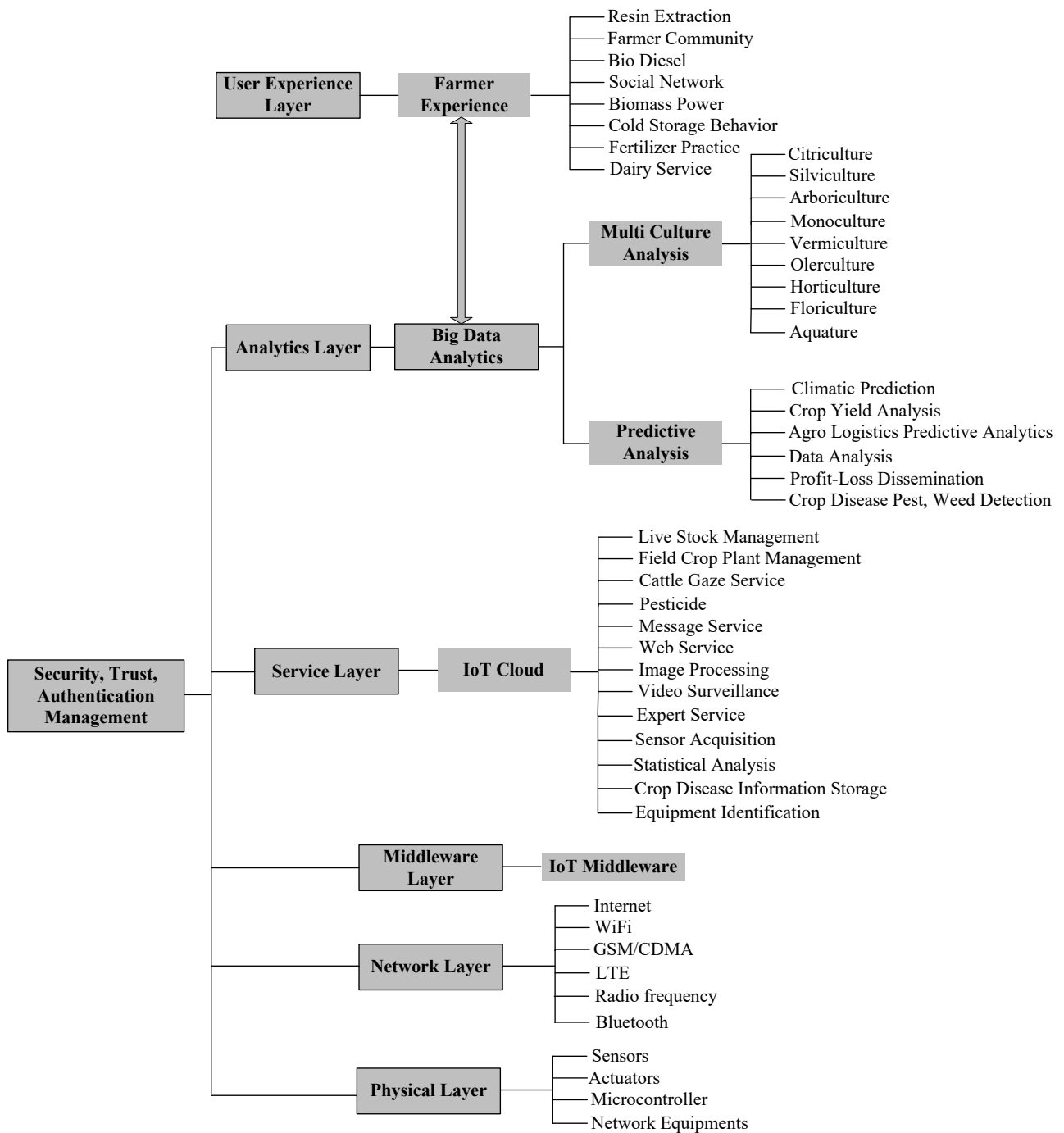

Figure 12. IoT based smart farming framework.

4.1. IoT Impact on Smart Vertical Farming Applications

The current world is the world of information technology. Information technology services are essential to improve lives and build a sustainable world. That is why information technology-based SF can bring new possibilities for improving the livelihood of rural and urban people. Providing timely, up-to-date information, marketing, storage technology through the IoT, mobile, according to the needs of the farmers, will play an important role in ensuring food security and improving the fortunes of the farmers [165–167]. One of the features of the IoT is that it can adapt to the environment and collect information from the environment leading to the application of a variety of such technologies in agriculture. The study in [168] indicated IoT had enhanced the conventional approach of SF, for example, nanotechnology which enables the creation of small cheap and sensors for IoT application.

The block diagram of agricultural trends in Figure 13 illustrates basic, low-cost technology relationships through VF, precision agriculture, automatic irrigation scheduling, plant growth optimization, farmland tracking, greenhouse monitoring, and crop farming process management [162,169]. The diagram of SF demonstrates the agriculture patterns accessible and low cost-effective interfaces via secured and faultless network across separate greenhouse, farmer, and field perceptions. Rural IoT systems that incorporate wireless devices allow real-time crop and animal monitoring. According to the figure, two sensor kits have been performed (Libelium Shrewd Agribusiness Xtreme IoT Vertical Unit and Edit/Plant Checking Sensor Pack), which measure soil moisture, leaf wetness, temperature, humidity, performance, and circulation. However, the MooMonitor sensor tracks the animal's health, reproduction, nutrition, rumination, and rest. Agriculture servers, gateways, and databases all play a key role in maintaining agriculture information and delivering rural resources on-demand to registered users. There are many applications, protocols, and templates in the farming sector as a whole. Among the trends of IoT, agriculture researches are focused on network platform, network design, software, stability, and challenges. IoT-based SF technology uses wireless devices to monitor and send real-time data through sensors presented in [170,171].

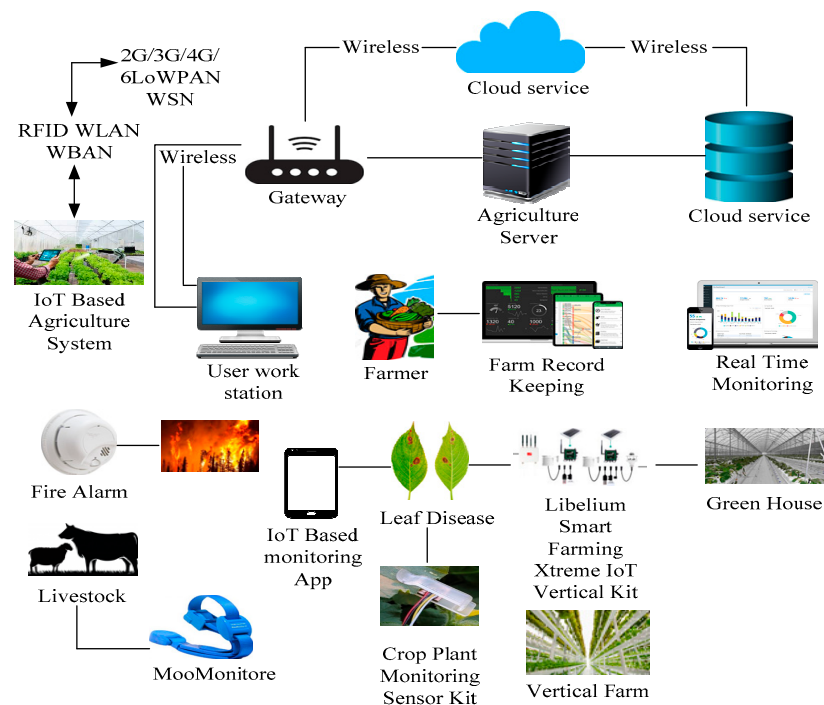

Figure 13. Smart farming trends.

4.2. IoT Potential for Smart Vertical Farming

USVF is an approach that uses information and communication technology to determine the exact amount of nutrients and materials needed to achieve maximum yields while maintaining crop and soil health and then apply them. It aims to make agriculture more sustainable, profitable, and environmentally friendly by reducing unnecessary expenses [172,173]. Usually, there are various amounts of IoT-based structures and applications that are widely used in USVF. Furthermore, IoT is the main controlling and monitoring gateway of smart VF. IoT aided farming exploration is to consolidate network stages and the engineering of the comparing platforms, applications, security problems, and difficulties, among others [149,150,157]. IoT is widely used in USVF. In fact, IoT is the main controlling and monitoring gateway of smart VF. IoT is a system where some devices can be connected through the Internet without human assistance and make decisions by analyzing the necessary data through intercommunication.

Many activities can be done without human intervention, from monitoring and analyzing weather data using IoT to setting the right time to plant crop seedlings, determine soil moisture, provide irrigation, determine the right amount of nutrients, apply fertilizers, and harvest crops. Figure 14 shows illustrate the major components of IoT-based SF [162]. The study in [174] presented user control yield through different sensors to monitor plants' health conditions after enabling IoT. In [175], the authors reported the concept of an SF to reduce conventional intercession, which measures various atmosphere parameters through IoT and sensors concept as indicated by plants prerequisites. In [176], the authors proposed an SF management system based on IoT. The study in [177] has addressed IoT-based SF where the user is able to know about crop statistical information, crop selection, weather situation, and predict the future harvest. In the work [178], the author indicated IoT brings massive improvement such as low-cost yield, optimize water use, sustain high yield, high-quality crop production in SF by examining many issues and challenges.

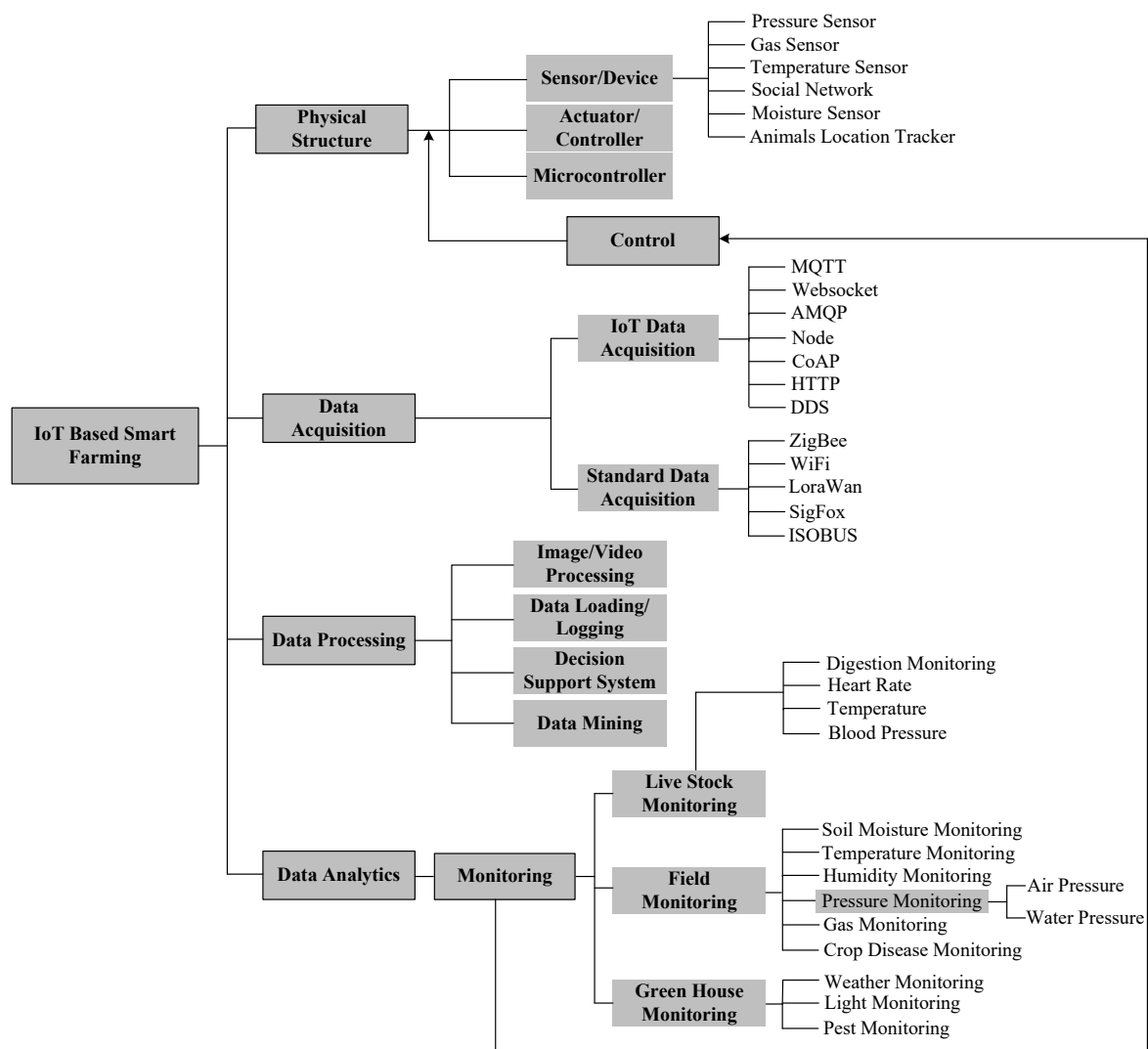

Figure 14. Significant elements of SF based on IoT.

4.3. IoT Based Smart Farming Sensor Systems

IoT is basically a data analytics technology that makes our activities easier and more dynamic through data collection, analysis and application. The use of sensor technology will increase manifold in the coming years. At the same time, technologies like IoT, machine learning and artificial intelligence (AI) will gain popularity, which will change our way of life [179,180]. With the upward thrust of new digital technologies in the agriculture

domain, there has been exceptional growth in the quantity of data that is being gathered by way of far-flung sensors, satellites and many others for exclusive functions. The role of AI in VF includes processes like monitoring the light condition, plant health, humidity, temperature, etc. The significant data that is being gathered ought to only serve fruitfully when the farmer is capable of obtaining a higher perception of various things involved with the farm. Therefore, to make sense out of it, this data is operated underneath a range of AI algorithms via which farmers can collect an applicable understanding of a variety of processes in general. By 2050, the planet is projected to need 50% more food than it currently produces. In this scenario, farmers will benefit from AI-enabled technologies by presenting higher yields and more sustainable resource use [181]. The work in [179] addressed an IoT technology with exceptional characters and capabilities to analyze and monitor data from sensors from remote areas such as optical, mechanical, and location used in the SF. IoT is one of the very high technology concepts in which devices are smarter, intelligent, low cost, long life, simple maintainers as well as sending informative data were presented in [182,183]. In [184], the authors indicated SF has the ability to deliver sustainability and beneficial production, which is founded on inventive technology, such as IoT. Sensor-based SF frameworks to offer an attractive solution for the farmer were presented in [185]. The work in [186] proposed IoT advancements can diminish the expense of labor cost, reduce the human effort and enhance the scale of sensor-based farming system by information assortment from sensors. Table 3 presents the primary applications and advantages of each IoT innovation in SF. IoT sensors technology presents the course of action of various components of an IoT and shows an ideal situation for SF. IoT, known as potential technology in VF in terms of various sensors uses, dynamic, quick decision-making, was present in [187,188]. In [189], the authors indicated IoT sensors topology had kept a huge contribution in SF in quick produce and profit with a short time. Figure 15 shows how SF collects data from various sensors such as moisture sensors, humidity sensors, temperature sensors, gas sensors, and pH sensors utilizing IoT devices. These ubiquitous SF topologies enhance data analysis and storage capacity, which able to connect with a different communication protocol such as a smartphone and computers.

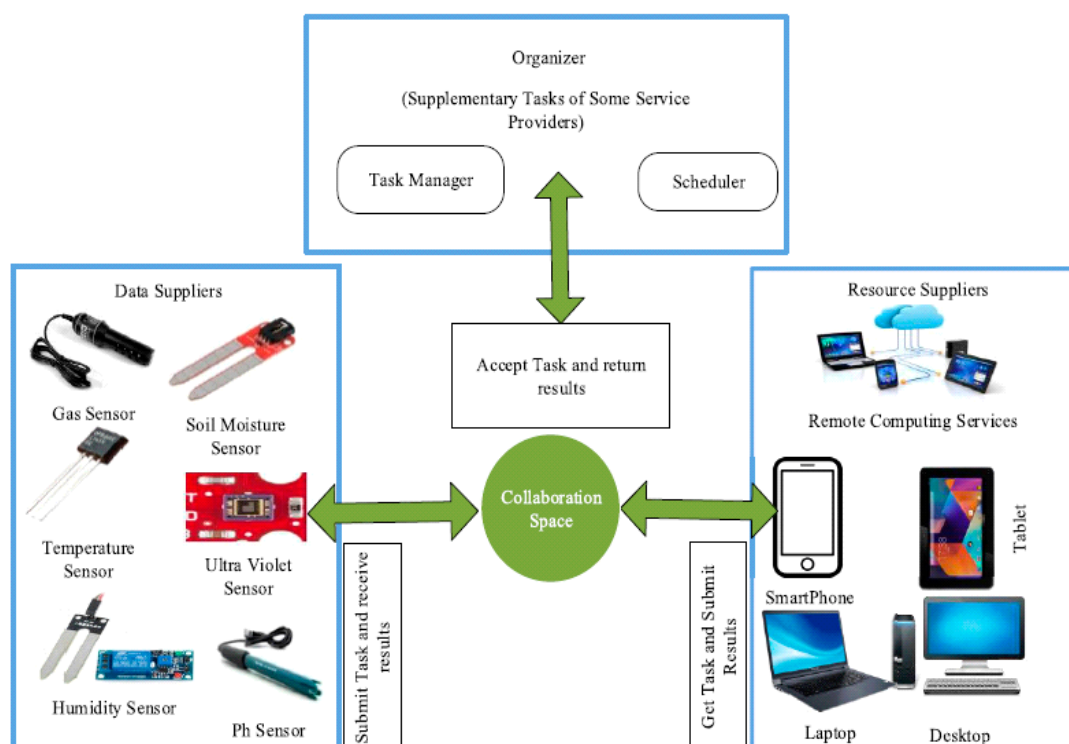

Figure 15. Block diagram of IoT-based smart farming solutions. Reprinted from ref. [162].

Table 3. IoT sensor categories utilized in smart farming.

Sensors Category	IoT Technologies	Operation	Advantages in Farming	Application in Agriculture
Optical	Wireless sensor network which communicates with sensors for data analysis and storage	Utilization of light to quantify soil properties	Simple analysis and collect data from sensors	Moisture of soil, natural issue and dampness substance soil
Tensiometer	Cloud computing is a model of Internet-based computing which helps to sense data from farming and storing	Utilization of tests to control soil compaction	Low cost to measure soil water and simple controlling system	Identifies the power utilized by the roots in water soak
Ion-selective field effect transistor sensors (ISFET)	Big data analytics which cycle of inspecting and examining huge data	Utilization of electrodes to identify explicit particles in the soil for efficient crop	The sensors make popularity as a biosensor in terms of food safety, crop security and low cost in smart farming application	Senses nitrogen phosphorus potassium in soil
Airflow	Embedded frameworks framework which comprises of both equipment and software	Estimate soil air porousness	Manufacture expenses can be diminished to an astounding level which will expand benefit and maintainability	Characterizes different soil sample, moisture stages, and soil formation/compaction
Location tracking	Communication protocols which foundation of IoT frameworks to enable network	Transfer data about the scope, longitude, position, and environment	Easy to identify position, time consuming, low cost and user friendly	The GPS gives exact point of farming

4.4. IoT Supported Hardware Utilized in Smart Farming

Numerous IoT-enabled hardware systems are available for use in agricultural realms. The following section denotes various hardware controller boards that are utilized for SF. A number of various IoT supported hardware platforms exist to be used within the agricultural domains. Table 4 categorizes current and legacy platforms based on main criteria [104,156,190,191].

Communication protocols are needed for IoT systems because they modify network connectivity and device coupling. Protocols for communication allow devices to share data over a network. The protocols define the formats for data transmission, data encoding, interface addressing systems, and packet routing from source to destination. Protocols also perform additional tasks such as sequence management, flow control, and packet retransmission. Table 5 compares multiple wireless networking systems based on a variety of criteria [156,192].

Many factors can affect the growth of plants, especially the environment. SF is a big way for better production within a short time as well as reduces human stress. Sensors are used in precision agriculture to collect data that enables farmers to easily track, manage, and optimize crops and adapt to evolving environmental factors through the implementation of smart technology such as IoT devices. Table 6 shows the list of sensor module that can be used in SF.

Table 4. IoT supported hardware controller board utilized in smart farming.

Parameters	Arduino		Raspberry Pi	ESPRESSIF
	Arduino Uno	Arduino Mega	Model 3 B+	
Microcontroller	ATmega328P	ATmega2560	Broadcom	ESP32
Operating Voltage	5 V	5 V	5 V	3.3 V
Input Voltage (Recommended)	7–12 V	7–12 V	2.5–3 A	2.3–3.6 V
Digital I/O Pins	14	54	40	39
PWM Digital I/O Pins	6	14		16
Analog Input Pins	6	16	8	12-bit,18 Channel
DC Current per I/O Pin	20 mA	20 mA		40 Ma
DC Current for 3.3V Pin	50 mA	50 mA	50 mA	50 Ma
Flash Memory	32 KB (0.5 KB used by the boot loader)	256 KB (8 KB used by the boot loader)	1 GB	4 MB
SRAM	2 KB (ATmega328P)	8 KB		520 KB
EEPROM	1KB (ATmega328P)	4 KB		523 Bytes
Clock Speed	16 MHz	16 MHz	1.4 GHz	240 MHz
LED_BUILTIN	13	13	-	
Length	68.6 mm	101.52 mm	85mm	
Width	53.4 mm	53.3 mm	55.8	
Weight	25 g	37 g	42 g	
USB ports	1 USB port to connect to the computer		4 USB ports for connecting a variety of devices.	1
Programming language	Arduino, C/C++		C, C++, Python, Ruby.	C/C++
Price	It is available for low cost		It is expensive.	Low-cost
IoT	Simple repetitive tasks that imply only a single action at a time		Faster and more powerful. Can handle multitasking and run more complex functionality.	Microcontrollers with integrated Wi-Fi and dual-mode Bluetooth that consume less power
Connection	External hardware is required to link to the internet, and this hardware is handled correctly with code.		Link to the Internet quickly and easily via Ethernet port and USB Wi-Fi dongles.	SPI(4), I2C(2), I2S(2), CAN, UART(3); Wi-Fi: 802.11 b/g/n Bluetooth: V4.2
Combination in Agriculture	Arduino boards can be used to read readings from various soil sensors, while a Raspberry Pi can serve as a think tank, determining how to act on the sensor data.			It is used to collect data from sensors such as LDRs (light dependent resistors), temperature sensors, and soil moisture sensors.

Table 5. A comparison of the emerging state of the art in networking technology.

Criteria	WiFi	WiMax	LR-WPAN	Mobile Communication	Bluetooth	LoRa
Standard	IEEE 802.11 a/c/b/d/g/n	IEEE 802.16	IEEE 802.15.4 (ZigBee)	2G-GSM, CDMA.-3GUMTS, CDMA2000, 4G-LTE	IEEE 802.15.1	LoRaWAN R1.0
Frequency Band	5 GHz–60 GHz	2 GHz–66 GH	868/915 MHz, 2.4 GHz	865 MHz, 2.4 GHz	2.4 GHz	868/900 MHz
Data Rate	1 Mb/s– 6.75 Gb/s	1 Mb/s–1 Gb/s (Fixed) 50–100 Mb/s (mobile)	40–250 Kb/s	2G: 50–100 kb/s 3G:200 kb/s 4G:0.1–1 Gb/s	1–24 Mb/s	0.3–50 Kb/s
Transmission Range	20–100 m	< 50 Km	10–20 m	The Whole Cellular Surface	8–10 m	<30 Km
Energy Consumption	Large	Average	Small	Moderate	Bluetooth: Moderate BLE: Very Small	Very Small
Expense	Large	Superior	Small	Moderate	Small	Superior

Table 6. Type of sensors in smart farming.

Hardware	References	Description/Functionality
DHT11 sensor	[104]	The DHT11 sensor farmers can monitor time-to-time insects in the plant leaf, measure temperature, soil, humanity, and claimed from their home through this sensor which is very helpful in remote areas.
Piezoelectric buzzer	[193]	A piezoelectric buzzer is one kind of sensor when sound is appalled, and it produces voltage. They are utilized in many fields such as energy harvesting, low power sensors, and also SF. Its application in SF to run low-power sensors reduces the dependency on the battery.
Electronic speed control	[21,194]	Conventional electronic speed controllers in farming control room temperature, motor speed and regulate the motor voltage. Using this device in modern farming plays an important role in terms of its large energy efficiency, less pollution, stability.

Agriculture operates somewhat differently today than it did a few decades before, primarily due to technical advancements such as sensors, processors, robots, and information technology. Agriculture now routinely makes use of emerging technology, including robotics, temperature and moisture sensors, aerial photography, and GPS. These advanced technologies, precision agriculture, and robotic systems allow businesses to operate more profitably, efficiently, safely, and sustainably. The primary objective of the Internet of things is to create a vast network by integrating various sensor devices such as GPS, remote sensing (RS), radio-frequency identification (RFID), laser scanners, and networks in order to comprehend the knowledge exchange of global things. IoT can refer to millions of networked embedded smart devices capable of accumulating data about themselves, their world, and other connected smart devices and linking this data to other devices and systems through the ubiquitous Internet [195].

Ambient daylight, ambient temperature, soil moisture, and humidity are all controllable parameters of vertical farming. In addition to the vertical columns, the ambient parameters must be controlled for each stack, necessitating the use of a separate collection of sensors for each vertical stack. These sensors produce a large amount of data, necessitating the use of an effective data management system. Numerous automation techniques are used to maximize resource use, including the integration of actuation by automated irrigation systems, as well as wireless monitoring via IoT in the VF, which is capable of managing sensor data effectively, identifying duplicate sensor readings, and visualizing it through web-based applications.

4.5. Secure Cloud on Smart Vertical Farming System

The growth of a country's population and massive industrial development, mainly in urban areas, lead to a variety of urbanization problems, including housing, food demands, schooling, health, and poverty. A new farming technique that utilizes minimal land area while producing a large crop with a secure aspect is highly desired. In [196], the authors addressed a two-factor authentication (2FA) scheme to bolster the system's security measures. Since the electronic device mounted on the indoor farming hydroponic system communicates over the Internet, the 2FA technique is used. Due to the fact that this hydroponic system would be installed inside the user's house, this electronic gadget will be wired to the user's home's network or WIFI. This linking of the computer to the Internet necessitates proper network protection to mitigate the possibility of data leakage and sabotage. The 2FA framework will be applied in this system through access codes generated by the gateway (NodeMCU) and a mobile application for access verification. Figure 16 illustrates the total security scheme's flowchart using a 2FA mechanism. It starts with the device module's controller demanding permission to send and receive data over the network via the ThingsSentral-based web module. ThingsSentral (TS) is a cloud-based IoT device network founded by Universiti Kebangsaan Malaysia. By supplying the user, program, and portal access code to the TS web service, the controller initiates the first authentication order. If the codes are valid, TS will send another authentication order. The second authentication process generates a request for verification and notification to the customer with a phone app that they must authenticate a request before the farming module can continue operating. The user will authenticate the order if approved, at which point TS will allow the remainder of the procedure before the controller explicitly stops it. If the customer fails to authenticate, the whole system is aborted, and the hydroponics module controller is informed of the request's denial.

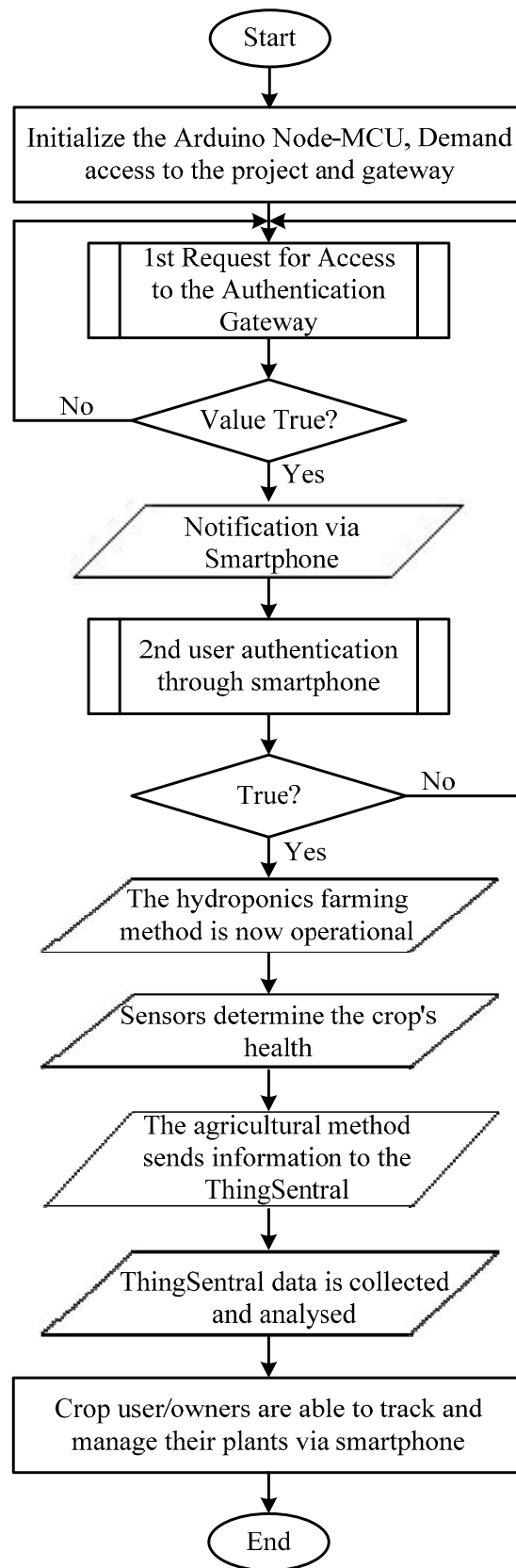

Figure 16. The flowchart’s overall design using a 2FA mechanism.

5. Social Acceptance of Urban Farming

The study in [197] addressed as far as a social responsibility of USVF contributes more in terms of reducing pollution, produce clean air and fresh food without using artificial fertilizer. The authors in [198] indicated USVF totally brings new technology to produce more food using less water, without soil which falls a very good impact on society. In [199], the authors reviewed 386 urban tenants in Berlin based on yield farming space capacity in an urban area, cost, human effort, and overall food production efficiency. While over 80% of the occupants favored VF on the rooftop of the building in terms of sufficient light facility, clean air, low pollution, environmental and financial benefits, fresh food, easy to monitor, simple maintenance, etc. Moreover, the greater part of the respondents was eager to purchase agricultural items. The study also reported in [199] presented a lack of food insecurity produced from VF of urban dwellers because of air contamination levels in urban areas. The work in [200] analyzed 18 rooftop farming leaves and soil conditions compared with the natural crop leaf and soil in Korea. The authors in [201] demonstrated the effect of rising temperatures on air quality at an outdoor rooftop farm atop a seven-story building in Brooklyn through an on-site observation attempt. In [202], the authors measured the pollution level, crop production costs, and monitoring capability in rooftop vegetable farms. Therefore, a USVF is required to overcome the problem such as air pollution, huge cost, sufficient food production, various type of crop production all season.

Advantages of Urban Smart Vertical Farming

Due to rapid urbanization, USVF has been introduced to achieve food security in an urban area. VF can be conceivably gainful in expanding crop production and adding to maintainable UF. Notable benefits of rising food inside the urban area can be helpful ecologically, socially, and monetarily. VF can also offer solutions for expanding food safety worldwide [203]. In [203], the authors indicated several advantages in USVF such as raise aesthetic beauty, energy generation, urban growth, organic food, preparation for the future, conservation of resources, VF flexibility, growing higher quality produce, and halting mass extinction. Besides, the study in [204] addressed that USVF has the benefit of absorbing polluted carbon-di-oxide from the air and increasing the level of pure oxygen in the air, environmentally friendly, helps to control air pollution and noise pollution. As a result, it has a fair weight to maintain air quality. The advantages of USVF protect large houses in the city from direct sunlight and helps to keep them cool, helps in air filtration by absorbing dust. On the other hand, the work in [205] addressed benefits of these USVF include protection from weather-related problems, utilize technologies and devices, helps in air filtration by absorbing dust, year-round production, huge food production within a small area of land.

In [206], the authors described a VF plant structure that delivers a controlled environment, the efficiency of farms would generally be autonomous of weather and secure from a weather-related problem. The work in [22] addressed VF can produce foods year-round. The study in [22] also presented some crops such as different vegetables, strawberries can produce all seasons of the year which provides benefit in terms of crops could be sold in the same infrastructures, they will not need to be transported between production and sale. Therefore, USVF provides less spoilage, reduces cost, infestation, and energy required than conventional farming encounters. The advantages of VF reduce the unemployment rate and make a new job opportunity for urban people who have less education and low experience. The study reported in [113] also presented a USVF with much flexibility for crop production, such as water protection, healthy food, cash income, not being labor-intensive, manageability, marketability, affordability, and sustainability urban growth. The authors also indicated VF utilize for drip and hydroponics crop production, which can save 50% lesser water than typical planting and can hold water. The study in [44] also reported delivering vegetables via VF is simply manageable and farmers do not need much focus on soil and plant during growing.

Bringing back vegetation in any approach definitely improves the quality of the urban environment, which is the main goal of urban VF. Urban agriculture via SF is also expected to provide environmental benefits to urban dwellers. The improvements in urban thermal performance and air quality reduce air temperature and energy usage for cooling loads. Despite providing food security for urbanites, this SF system also able to promote a conducive and liveable living urban environment. VF can manage by family workers such as old people, women, young persons because of clean, safe, less dust, ease to marketability with high profit. All these benefits indicated a significant impact on the application of UF in the city context. USVF is to provide efficient and effective extension services based on the needs of all classes of growers so that they can make the best use of their resources and contribute to sustainable agricultural and socio-economic development.

6. Issues and Challenges

VF technology plays an essential role in reducing future food demand, which is one of the world's biggest problems today. However, existing VF technology faces few challenges due to various issues, such as high starting cost, low yield variability, energy reliance and utilization, producing heat by artificial lighting was presented in [41,71,73,74]. In [73,74], the authors reported VF technology would be gradually becoming a non-profit industry if not focus on addressing the current issues such as energy use, pollution, economy. As a result, current farming is heading for a crisis due to the evils of climate change and the lack of significant response to the use of more materials. As a result of high production costs and the adverse effects of harmful chemicals used in agriculture on the environment, smart technology's high-material grain production technologies do not seem to be viable enough to meet the needs of a growing population. Future crop production is considered to be very risky due to the prevalence of diseases and inorganic impacts in the changing climate.

Other than that, equipment location, space, and environmental issues have to be taken seriously depending on VF's design to maximize crop production. Additionally, shape considerations such as the form and dimensions of the increasing installation, as well as the spacing between plants, are a source of difficulty for VF. Leafy greens and herbs, for example, the needless vertical spacing between tiers of a vertical rack than flowers or fruit plants. Additionally, lighting systems should be evaluated for their heat management characteristics and configured to mitigate the warmth generated by VF in order to minimize any possible adverse effect on development, while allowing for adequate air circulation and ventilation. It is crucial to keep in mind that, while food developed using VF techniques may be safer to eat than food grown conventionally, hazards may still exist during the growing phase. Dirt and microorganisms from employees, environmental hazards in the nutrient medium, water cleanliness and protection, and post-farm handling activities such as sorting, trimming, and transportation are all examples of such risks. Thus, food safety management methods such as hazard analysis critical control point analysis, as well as food safety assessment and testing, are critical in VF, just as they are in traditional agriculture.

7. Conclusions and Recommendations

USVF is a current improvement that shows promise for the future. They will be open to the insistent and additional combination of current technologies and in turn use growing convenience and reduce the effort for humans. This review considers the diverse ways of how a USVF may be monitored, controlled, and built using the IoT, AI, and sensors. The continuous flow of real data accrued from various sensors or systems deployed in a USVF is analyzed, and suitable actions must be engaged. Although numerous trends exist, only a few are being utilized, and they suffer from certain drawbacks. Thus, the utilization of smart technology shows better performance compared with the existing techniques.

The aim of this study is to recognize SF by conducting a comprehensive analysis of the state-of-the-art of IoT in USVF and identifying the most commonly used hardware, platforms, network protocols, and technologies, as well as their applicability to the proposed solution. AI and image processing techniques have become more prevalent in recent work

to develop intelligent farming management. According to the listed IoT applications for SF, the most prevalent application is crop monitoring. Significant advancements in technical applications have made it possible to integrate and link multiple sensors in networks quickly. The microcontroller has been instrumental in the rapid growth of IoT projects, especially in the field of precision agriculture.

Based on the literature survey, many past research works are summarized along with the various sensor types, technology, and techniques that are suitable for the research. This paper reviews the USVF sensors categories, IoT technology, and hardware components suitable for monitoring and controlling water level, crop health condition, moisture of soil, production of yield and environment. The paper has also focused on a comprehensive explanation of USVF technologies, monitor and control operation, smart automation, structure, materials, social acceptance, benefit, issues, and various trends and applications. Finally, the study is suggested constructing a pervasive automation system USVF that reduces human intervention to a minimum.

The review has proposed some significant and selective suggestions for the further technological developments of USVF based on summarizing, synthesize and viewpoint from the reviewed literature. Some possible improvements have been addressed in this review below:

- Focusing on food production via USVF activities than using other conventional methods in the city, as mentioned in [7,25,203], USVF produces crops throughout the year, with greater control over food safety. This will reduce dependency on imported vegetables.
- Enhance the user control panel for non-technical users who use SF. As a result, it is preferable to develop a user-friendly interface for powerful applications in a control panel and based on user experience.
- Appropriate IoT architecture must be built to address the issue of partitioned land cultivation, which is a concern in several countries around the world. Adequate strategy and preparations should be implemented in advance to address this problem.
- By combining big data analytics and cloud-based computing, a decision support framework can be developed to improve and forecast futuristic yield estimation in crop productivity, quality prediction, crop risk prevention, and irregular growth.
- Remote-controlled field crop planting systems must be built in such a way that automated planting machines can plate farmers more efficiently in the field. Cloud monitoring and remote multi-device visualization have advanced to the point where operators/owners can track real-time manipulation.
- Having a real-time livestock tracking system that enables cloud services to improve the farmer's economic position intuitively. One basic limitation of the majority of IoT systems was their inability to conduct rapid data processing over a wide range of sensor data sources.
- Use big data analytics to address disease management problems across many crops and to create a consolidated farming machinery control system suitable for large-scale agriculture.
- Develop a predictive method for determining the pollination time.
- Develop cost management strategies for large-scale agricultural industries dependent on big data analytics.
- Provide an easy-to-use climatic knowledge analytic service for farmers.
- Analyze the profit margins of agri-products using big data modeling and a supply chain management framework.
- Analytics can provide farmers with prior knowledge of the potential rot time of agricultural products, thereby reducing loss and increasing benefit in terms of value.
- Develop a smart cell phone application to boost the physical farming situation.
- Develop a web-based scheduling system for pesticide sprays based on crop type, rate, and time.

- Create a warning system, as most systems use warnings to inform the operator/farmer of critical events.
- Establish irrigation schedules based on sensor data and current weather forecasts. Irrigation is often applied using sensor data to predict the required amount of water and electricity accurately. Irrigation schemes, for example, often make use of real-time weather forecasts to minimize water and energy consumption and prevent excessive irrigation.
- Device security is a critical issue. Develop a two-factor authentication scheme to bolster the protection of the affordable indoor hydroponic system.
- Additional research should be conducted on plants' tolerance for elevated EC and/or pH. Knowing how resistant plants are to extreme pH levels enables device designers to create solutions that handle hydroponic systems efficiently.
- Drone based pesticide sprayer can be made for an automatic spray of pesticides and fertilizers to get better quality of crops with increased quantity. It could help the farmers to spray pesticides evenly throughout their agricultural lands.
- For a smart storage house, we can install humidity and temperature sensors that can automatically turn the exhaust fan ON when certain humidity or temperature reaches the temperature danger zone for food. For food, this danger temperature zone is between 41 and 135 degrees for height.
- For water and food control for cattle, we can use conveyor belts to automatically supply food to cattle.
- Increase in monetary income for urban dwellers that uses the smart urban farming system to grow vegetables and sells unconsumed vegetables.
- We can install a biogas plant in the farmhouse to meet all the electric requirements and to fully use the waste materials of cattle.
- We can also install a circuit to automatically get the power meter reading and electricity bills on our cell phone and hence get up to date about the power consumption of USVF.
- Atmospheric pollutants due to being in an urban environment have a negative effect on the plants, therefore by providing sufficient water to plants (this aids in pollution removal and temperature reduction), we utilize long-lived and low-maintenance trees.
- Utilize carbon-based nanomaterials can be used as gas sensors to combat air pollution, which has a detrimental effect on plant health, by detecting and quantifying polluting gases, primarily hydrogen sulfide (H₂S) and carbon monoxide (CO) based in [107,108].

Author Contributions: Writing—original draft preparation, M.R.S., and M.H.M.S.; writing—review and editing, M.R.S., N.M.H. and M.H.M.S.; project administration, M.H.M.S.; funding acquisition, M.H.M.S. All authors have read and agreed to the published version of the manuscript.

Funding: This work was carried out with the financial support from the Ministry of Higher Education of Malaysia under the research grant LRGS/1/2019/UKM-UKM/5/2.

Conflicts of Interest: The authors declare no conflict of interest.

References

1. Avtar, R.; Tripathi, S.; Aggarwal, A.K.; Kumar, P. Population–Urbanization–Energy Nexus: A Review. *Resources* **2019**, *8*, 136. [CrossRef]
2. Jayne, T.S.; Chamberlin, J.; Headey, D.D. Land pressures, the evolution of farming systems, and development strategies in Africa: A synthesis. *Food Policy* **2014**, *48*, 1–17. [CrossRef]
3. Lajoie-O'Malley, A.; Bronson, K.; van der Burg, S.; Klerkx, L. The future(s) of digital agriculture and sustainable food systems: An analysis of high-level policy documents. *Ecosyst. Serv.* **2020**, *45*, 101183. [CrossRef]
4. Lezoche, M.; Panetto, H.; Kacprzyk, J.; Hernandez, J.E.; Alemany Díaz, M.M.E. Agri-Food 4.0: A survey of the Supply Chains and Technologies for the Future Agriculture. *Comput. Ind.* **2020**, *117*, 103187. [CrossRef]
5. Lu, C.; Grundy, S. Urban Agriculture and Vertical Farming. In *Encyclopedia of Sustainable Technologies*; Elsevier: Amsterdam, The Netherlands, 2017; pp. 393–402.

6. Li, L.; Li, X.; Chong, C.; Wang, C.H.; Wang, X. A decision support framework for the design and operation of sustainable urban farming systems. *J. Clean. Prod.* **2020**, *268*, 121928. [CrossRef]
7. Al-Kodmany, K. The Vertical Farm: A Review of Developments and Implications for the Vertical City. *Buildings* **2018**, *8*, 24. [CrossRef]
8. Projected Vertical Farming Market Worldwide in 2019 and 2025. Available online: <https://www.statista.com/statistics/487666/projection-vertical-farming-market-worldwide/> (accessed on 1 May 2021).
9. Dardak, R.A.; Adham, K.A. Transferring Agricultural Technology from Government Research Institution to Private Firms in Malaysia. *Procedia Soc. Behav. Sci.* **2014**, *115*, 346–360. [CrossRef]
10. Alam, A.S.A.F.; Begum, H.; Masud, M.M.; Al-Amin, A.Q.; Filho, W.L. Agriculture insurance for disaster risk reduction: A case study of Malaysia. *Int. J. Disaster Risk Reduct.* **2020**, *47*, 101626. [CrossRef]
11. Tian, H.; Wang, T.; Liu, Y.; Qiao, X.; Li, Y. Computer vision technology in agricultural automation—A review. *Inf. Process. Agric.* **2020**, *7*, 1–19. [CrossRef]
12. Jha, K.; Doshi, A.; Patel, P.; Shah, M. A comprehensive review on automation in agriculture using artificial intelligence. *Artif. Intell. Agric.* **2019**, *2*, 1–12. [CrossRef]
13. Puranik, V.; Sharmila, A.; Ranjan, A.; Kumari, A. Automation in Agriculture and IoT. In Proceedings of the 2019 4th International Conference on Internet of Things: Smart Innovation and Usages, IoT-SIU 2019, Ghaziabad, India, 18–19 April 2019.
14. Dubois, A.; Teytaud, F.; Verel, S. Short term soil moisture forecasts for potato crop farming: A machine learning approach. *Comput. Electron. Agric.* **2021**, *180*, 105902. [CrossRef]
15. Sabri, N.S.A.; Zakaria, Z.; Mohamad, S.E.; Jaafar, A.B.; Hara, H. Importance of soil temperature for the growth of temperate crops under a tropical climate and functional role of soil microbial diversity. *Microbes Environ.* **2018**, *33*, 144–150. [CrossRef]
16. Lu, Y.; Xu, X.; Wang, L. Smart manufacturing process and system automation—A critical review of the standards and envisioned scenarios. *J. Manuf. Syst.* **2020**, *56*, 312–325. [CrossRef]
17. Ramin Shamshiri, R.; Kalantari, F.; Ting, K.C.; Thorp, K.R.; Hameed, I.A.; Weltzien, C.; Ahmad, D.; Mojgan Shad, Z. Advances in greenhouse automation and controlled environment agriculture: A transition to plant factories and urban agriculture. *Int. J. Agric. Biol. Eng.* **2018**, *11*, 1–22. [CrossRef]
18. Gorjian, S.; Minaei, S.; MalehMirchegini, L.; Trommsdorff, M.; Shamshiri, R.R. Applications of solar PV systems in agricultural automation and robotics. In *Photovoltaic Solar Energy Conversion*; Elsevier: Amsterdam, The Netherlands, 2020; pp. 191–235.
19. Ju, C.; Son, H. Multiple UAV Systems for Agricultural Applications: Control, Implementation, and Evaluation. *Electronics* **2018**, *7*, 162. [CrossRef]
20. Wood, L. *Agricultural Robots and Drones 2018–2038: Technologies, Markets and Players*; IDTechEx: Boston, MA, USA, 2018.
21. Lakhari, I.A.; Jianmin, G.; Syed, T.N.; Chandio, F.A.; Buttar, N.A.; Qureshi, W.A. Monitoring and control systems in agriculture using intelligent sensor techniques: A review of the aeroponic system. *J. Sensors* **2018**, *2018*, 8672769. [CrossRef]
22. Avgoustaki, D.D.; Xydis, G. *How Energy Innovation in Indoor Vertical Farming can Improve Food Security, Sustainability, and Food Safety*; Elsevier: Amsterdam, The Netherlands, 2020; Volume 5, pp. 1–51.
23. Castañeda-Miranda, A.; Castaño-Meneses, V.M. Internet of things for smart farming and frost intelligent control in greenhouses. *Comput. Electron. Agric.* **2020**, *176*, 105614. [CrossRef]
24. Li, X.; Ma, Z.; Zheng, J.; Liu, Y.; Zhu, L.; Zhou, N. An Effective Edge-Assisted Data Collection Approach for Critical Events in the SDWSN-Based Agricultural Internet of Things. *Electronics* **2020**, *9*, 907. [CrossRef]
25. Kalantari, F.; Mohd Tahir, O.; Mahmoudi Lahijani, A.; Kalantari, S. A Review of Vertical Farming Technology: A Guide for Implementation of Building Integrated Agriculture in Cities. *Adv. Eng. Forum* **2017**, *24*, 76–91. [CrossRef]
26. Beacham, A.M.; Vickers, L.H.; Monaghan, J.M. Vertical farming: A summary of approaches to growing skywards. *J. Hortic. Sci. Biotechnol.* **2019**, *94*, 277–283. [CrossRef]
27. Miller, A. Vertical Farming and Hydroponics on the Spectrum of Sustainability-Sustainable Food Trust-Sustainable Food Trust. Available online: <https://sustainablefoodtrust.org/articles/vertical-farming-and-hydroponics-on-the-spectrum-of-sustainability/> (accessed on 1 May 2021).
28. Vertical Farms, Building a Viable Indoor Farming Model for Cities. Available online: <https://journals.openedition.org/factsreports/5737> (accessed on 20 December 2020).
29. Royston, R.M.; Pavithra, M.P. Vertical Farming A Concept. *Int. J. Eng. Tech.* **2018**, *4*, 500–506.
30. Gentry, M. Local heat, local food: Integrating vertical hydroponic farming with district heating in Sweden. *Energy* **2019**, *174*, 191–197. [CrossRef]
31. Gerarden, T.D.; Newell, R.G.; Stavins, R.N. *Assessing the Energy and Environmental Performance of Vertical Hydroponic Farming*; IVL: Stockholm, Sweden, 2015; ISBN 9789188787354.
32. Barbosa, G.L.; Almeida Gadelha, F.D.; Kublik, N.; Proctor, A.; Reichelm, L.; Weissinger, E.; Wohlleb, G.M.; Halden, R.U. Comparison of land, water, and energy requirements of lettuce grown using hydroponic vs. Conventional agricultural methods. *Int. J. Environ. Res. Public Health* **2015**, *12*, 6879–6891. [CrossRef]
33. Stein, E.W. The Transformative Environmental Effects Large-Scale Indoor Farming May Have On Air, Water, and Soil. *Air Soil Water Res.* **2021**, *14*, 1178622121995819. [CrossRef]

34. Fernández-Cabanás, V.M.; Pérez-Urrestarazu, L.; Juárez, A.; Kaufman, N.T.; Gross, J.A. Comparative Analysis of Horizontal and Vertical Decoupled Aquaponic Systems for Basil Production and Effect of Light Supplementation by LED. *Agronomy* **2020**, *10*, 1414. [[CrossRef](#)]
35. Germer, J.; Sauerborn, J.; Asch, F.; de Boer, J.; Schreiber, J.; Weber, G.; Müller, J. Skyfarming an ecological innovation to enhance global food security. *J. Verbrauch. Leb.* **2011**, *6*, 237–251. [[CrossRef](#)]
36. Chatterjee, A.; Debnath, S.; Pal, H. Implication of Urban Agriculture and Vertical Farming for Future Sustainability. In *Urban Horticulture-Necessity of the Future*; IntechOpen: London, UK, 2020.
37. De Oliveira, F.B.; Forbes, H.; Schaefer, D.; Syed, J.M. Lean principles in vertical farming: A case study. In *Procedia CIRP, Proceedings of the 53rd CIRP Conference on Manufacturing Systems, Chicago, IL, USA, 1–3 July 2020*; Elsevier: Amsterdam, The Netherlands, 2020; Volume 93, pp. 712–717.
38. Arnalte-Mur, L.; Ortiz-Miranda, D.; Cerrada-Serra, P.; Martínez-Gómez, V.; Moreno-Pérez, O.; Barbu, R.; Bjorkhaug, H.; Czekaj, M.; Duckett, D.; Galli, F.; et al. The drivers of change for the contribution of small farms to regional food security in Europe. *Glob. Food Sec.* **2020**, *26*, 100395. [[CrossRef](#)]
39. De Amorim, W.S.; Borchardt Deggau, A.; do Livramento Gonçalves, G.; da Silva Neiva, S.; Prasath, A.R.; de Andrade Guerra, J.B.S.O. Urban challenges and opportunities to promote sustainable food security through smart cities and the 4th industrial revolution. *Land Use Policy* **2019**, *87*, 104065. [[CrossRef](#)]
40. Ferrante, A. The Framework of Urban Built Environments. In *Towards Nearly Zero Energy*; Elsevier: Amsterdam, The Netherlands, 2016; pp. 1–63.
41. Khan, R.; Aziz, Z.; Ahmed, V. Building integrated agriculture information modelling (BIAIM): An integrated approach towards urban agriculture. *Sustain. Cities Soc.* **2018**, *37*, 594–607. [[CrossRef](#)]
42. Benis, K.; Reinhart, C.; Ferrão, P. Development of a simulation-based decision support workflow for the implementation of Building-Integrated Agriculture (BIA) in urban contexts. *J. Clean. Prod.* **2017**, *147*, 589–602. [[CrossRef](#)]
43. Mašková, L.; Simmons, R.W.; De Baets, S.; Montero, E.M.; Delmer, A.; Sakrabani, R. Assessment of silt from sand and gravel processing as a suitable sub-soil material in land restoration: A glasshouse study. *Chemosphere* **2019**, *219*, 58–65. [[CrossRef](#)]
44. Subić, J.; Nastić, L.; Bekić, B. Economic Effects of Using Geothermal Waters in the Production of Flowers and Vegetables in Glasshouses. *Procedia Econ. Financ.* **2015**, *22*, 131–140. [[CrossRef](#)]
45. Benis, K.; Ferrão, P. Commercial farming within the urban built environment—Taking stock of an evolving field in northern countries. *Glob. Food Sec.* **2018**, *17*, 30–37. [[CrossRef](#)]
46. Mehanna, W.A.E.H.; Mehanna, W.A.E.H. Urban renewal for traditional commercial streets at the historical centers of cities. *Alex. Eng. J.* **2019**, *58*, 1127–1143. [[CrossRef](#)]
47. Dos Santos, M.J.P.L. Smart cities and urban areas—Aquaponics as innovative urban agriculture. *Urban For. Urban Green.* **2016**, *20*, 402–406. [[CrossRef](#)]
48. Benis, K.; Reinhart, C.; Ferrão, P. Building-Integrated Agriculture (BIA) in Urban Contexts: Testing A Simulation-Based Decision Support Workflow. *Build. Simul.* **2017**, *10*, 7–9.
49. El-Kazzaz, K.A.; El-Kazzaz, A. Soilless Agriculture a New and Advanced Method for Agriculture Development: An Introduction. *Agric. Res. Tech.* **2017**, *3*, 63–72.
50. Kim, E.; Jung, J.; Hapsari, G.; Kang, S.; Kim, K.; Yoon, S.; Lee, M.; Han, M.; Choi, Y.; Choe, J.K. Economic and environmental sustainability and public perceptions of rooftop farm versus extensive garden. *Build. Environ.* **2018**, *146*, 206–215. [[CrossRef](#)]
51. Majid, M.; Khan, J.N.; Ahmad Shah, Q.M.; Masoodi, K.Z.; Afroza, B.; Parvaze, S. Evaluation of hydroponic systems for the cultivation of Lettuce (*Lactuca sativa* L., var. *Longifolia*) and comparison with protected soil-based cultivation. *Agric. Water Manag.* **2020**, *245*, 106572. [[CrossRef](#)]
52. Magwaza, S.T.; Magwaza, L.S.; Odindo, A.O.; Mditshwa, A. Hydroponic technology as decentralised system for domestic wastewater treatment and vegetable production in urban agriculture: A review. *Sci. Total Environ.* **2020**, *698*, 134154. [[CrossRef](#)]
53. Wong, C.E.; Teo, Z.W.N.; Shen, L.; Yu, H. Seeing the lights for leafy greens in indoor vertical farming. *Trends Food Sci. Technol.* **2020**, *106*, 48–63. [[CrossRef](#)]
54. Nwoba, E.G.; Parlevliet, D.A.; Laird, D.W.; Alameh, K.; Moheimani, N.R. Light management technologies for increasing algal photobioreactor efficiency. *Algal Res.* **2019**, *39*, 101433. [[CrossRef](#)]
55. Bantis, F.; Smirnakou, S.; Ouzounis, T.; Koukounaras, A.; Ntagkas, N.; Radoglou, K. Current status and recent achievements in the field of horticulture with the use of light-emitting diodes (LEDs). *Sci. Hortic.* **2018**, *235*, 437–451. [[CrossRef](#)]
56. Kozai, T.; Niu, G. Role of the plant factory with artificial lighting (PFAL) in urban areas. In *Plant Factory: An Indoor Vertical Farming System for Efficient Quality Food Production*, 2nd ed.; Elsevier: Amsterdam, The Netherlands, 2019; pp. 7–34.
57. Promratrak, L. The effect of using led lighting in the growth of crops hydroponics. *Int. J. Smart Grid Clean Energy* **2017**, *6*, 133–140. [[CrossRef](#)]
58. Kobayashi, K.; Amore, T.; Lazaro, M. Light-Emitting Diodes (LEDs) for Miniature Hydroponic Lettuce. *Opt. Photonics J.* **2013**, *3*, 74–77. [[CrossRef](#)]
59. Tablada, A.; Kosorić, V.; Huang, H.; Lau, S.S.Y.; Shabunko, V. Architectural quality of the productive façades integrating photovoltaic and vertical farming systems: Survey among experts in Singapore. *Front. Archit. Res.* **2020**, *9*, 301–318. [[CrossRef](#)]

60. Cho, J.; Park, S.M.; Park, A.R.; Lee, O.C.; Nam, G.; Ra, I.-H. Application of Photovoltaic Systems for Agriculture: A Study on the Relationship between Power Generation and Farming for the Improvement of Photovoltaic Applications in Agriculture. *Energies* **2020**, *13*, 4815. [CrossRef]
61. Tuomisto, H.L. Vertical Farming and Cultured Meat: Immature Technologies for Urgent Problems. *One Earth* **2019**, *1*, 275–277. [CrossRef]
62. Munir, M.S.; Bajwa, I.S.; Cheema, S.M. An intelligent and secure smart watering system using fuzzy logic and blockchain. *Comput. Electr. Eng.* **2019**, *77*, 109–119. [CrossRef]
63. Agriculture 4.0–The Future of Farming Technology. Available online: <https://www.worldgovernmentsummit.org/api/publications/document?id=95df8ac4-e97c-6578-b2f8-ff0000a7ddb6> (accessed on 1 May 2021).
64. Sishodia, R.P.; Ray, R.L.; Singh, S.K. Applications of Remote Sensing in Precision Agriculture: A Review. *Remote Sens.* **2020**, *12*, 3136. [CrossRef]
65. Aruna, M.S.; Pradesh, M. A Review: The application of Remote Sensing, GIS and GPS in Precision Agriculture. *J. Adv. Technol. Eng. Res.* **2012**, *2*, 50–54.
66. Chuah, Y.D.; Lee, J.V.; Tan, S.S.; Ng, C.K. Implementation of smart monitoring system in vertical farming. In *IOP Conference Series: Earth and Environmental Science, Proceedings of the International Conference on Sustainable Energy and Green Technology, Kuala Lumpur, Malaysia, 11–14 December 2018*; IOP Publishing Ltd.: Bristol, UK, 2018; Volume 268, p. 12083.
67. Fountas, S.; Mylonas, N.; Malounas, I.; Rodias, E.; Hellmann Santos, C.; Pekkeriet, E. Agricultural Robotics for Field Operations. *Sensors* **2020**, *20*, 2672. [CrossRef] [PubMed]
68. Antonacci, A.; Arduini, F.; Moscone, D.; Paleschi, G.; Scognamiglio, V. Nanostructured (Bio) sensors for smart agriculture. *Trends Anal. Chem.* **2018**, *98*, 95–103. [CrossRef]
69. Kalantari, F.; Tahir, O.M.; Joni, R.A.; Fatemi, E. Opportunities and challenges in sustainability of vertical farming: A review. *J. Landsc. Ecol.* **2018**, *11*, 35–60. [CrossRef]
70. Rettore de Araujo Zanella, A.; da Silva, E.; Pessoa Albini, L.C. Security challenges to Smart Agriculture: Current State, Key Issues, and Future Directions. *Array* **2020**, *8*, 100048. [CrossRef]
71. Singh, N.; Singh, A.N. Odysseys of agriculture sensors: Current challenges and forthcoming prospects. *Comput. Electron. Agric.* **2020**, *171*, 105328. [CrossRef]
72. Sivamani, S.; Bae, N.; Cho, Y. A Smart Service Model Based on Ubiquitous Sensor Networks Using Vertical Farm Ontology. *Int. J. Distrib. Sens. Netw.* **2013**, *9*, 161495. [CrossRef]
73. Viscarra Rossel, R.A.; Bouma, J. Soil sensing: A new paradigm for agriculture. *Agric. Syst.* **2016**, *148*, 71–74. [CrossRef]
74. Zhou, W.; Xu, Z.; Ross, D.; Dignan, J.; Fan, Y.; Huang, Y.; Wang, G.; Bagtzoglou, A.C.; Lei, Y.; Li, B. Towards water-saving irrigation methodology: Field test of soil moisture profiling using flat thin mm-sized soil moisture sensors (MSMSs). *Sens. Actuators B Chem.* **2019**, *298*, 126857. [CrossRef]
75. Martínez, G.; Laguna, A.M.; Giráldez, J.V.; Vanderlinden, K. Concurrent variability of soil moisture and apparent electrical conductivity in the proximity of olive trees. *Agric. Water Manag.* **2020**, *245*, 106652. [CrossRef]
76. Yang, R.; Liu, F.; Zhang, G.; Zhao, Y.; Li, D.; Yang, J.; Yang, F.; Yang, F. Mapping Soil Texture Based on Field Soil Moisture Observations at a High Temporal Resolution in an Oasis Agricultural Area. *Pedosphere* **2016**, *26*, 699–708. [CrossRef]
77. Ravansari, R.; Wilson, S.C.; Wilson, B.R.; Tighe, M. Rapid PXRF soil organic carbon and organic matter assessment using novel modular radiation detector assembly. *Geoderma* **2021**, *382*, 114728. [CrossRef]
78. Frazão, J.; de Goede, R.G.M.; Capowiez, Y.; Pulleman, M.M. Soil structure formation and organic matter distribution as affected by earthworm species interactions and crop residue placement. *Geoderma* **2019**, *338*, 453–463. [CrossRef]
79. Aparicio, V.C.; Zamora, M.; Barbera, A.; Castro-Franco, M.; Domenech, M.; De Gerónimo, E.; Costa, J.L. Industrial agriculture and agroecological transition systems: A comparative analysis of productivity results, organic matter and glyphosate in soil. *Agric. Syst.* **2018**, *167*, 103–112.
80. Saeed, I.A.; Wang, M.; Ren, Y.; Shi, Q.; Malik, M.H.; Tao, S.; Cai, Q.; Gao, W. Performance analysis of dielectric soil moisture sensor. *Soil Water Res.* **2019**, *14*, 195–199. [CrossRef]
81. Shi, W.; Zhang, S.; Wang, M.; Zheng, W. Design and performance analysis of soil temperature and humidity sensor. *IFAC Pap. Online* **2018**, *51*, 586–590. [CrossRef]
82. Surya, S.G.; Yuvaraja, S.; Varrla, E.; Baghini, M.S.; Palaparthi, V.S.; Salama, K.N. An in-field integrated capacitive sensor for rapid detection and quantification of soil moisture. *Sens. Actuators B Chem.* **2020**, *321*, 128542. [CrossRef]
83. Deng, X.; Gu, H.; Yang, L.; Lyu, H.; Cheng, Y.; Pan, L.; Fu, Z.; Cui, L.; Zhang, L. A method of electrical conductivity compensation in a low-cost soil moisture sensing measurement based on capacitance. *Meas. J. Int. Meas. Confed.* **2020**, *150*, 107052. [CrossRef]
84. Scheberl, L.; Scharenbroch, B.C.; Werner, L.P.; Prater, J.R.; Fite, K.L. Evaluation of soil pH and soil moisture with different field sensors: Case study urban soil. *Urban For. Urban Green.* **2019**, *38*, 267–279. [CrossRef]
85. Shahrulakram, M.A.I.; Johari, J. *Water Storage Monitoring System with pH Sensor for Pharmaceutical Plants*; Institute of Electrical and Electronics Engineers (IEEE): Piscataway, NJ, USA, 2017; pp. 46–52.
86. Vivaldi, F.; Santalucia, D.; Poma, N.; Bonini, A.; Salvo, P.; Del Noce, L.; Melai, B.; Kirchhain, A.; Kolivoška, V.; Sokolová, R.; et al. A voltammetric pH sensor for food and biological matrices. *Sens. Actuators B Chem.* **2020**, *322*, 128650. [CrossRef]
87. Serrano-Finetti, E.; Aliau-Bonet, C.; López-Lapeña, O.; Pallàs-Areny, R. Cost-effective autonomous sensor for the long-term monitoring of water electrical conductivity of crop fields. *Comput. Electron. Agric.* **2019**, *165*, 104940. [CrossRef]

88. Ratnaparkhi, S.; Khan, S.; Arya, C.; Khapre, S.; Singh, P.; Diwakar, M.; Shankar, A. Smart agriculture sensors in IOT: A review. *Mater. Today Proc.* 2020; in press.
89. Visconti, F.; de Paz, J.M. Electrical Conductivity Measurements in Agriculture: The Assessment of Soil Salinity. In *New Trends and Developments in Metrology*; InTech: London, UK, 2016.
90. Panigrahi, S. Smart Farming: IOT Based Smart Sensor Agriculture Stick For Live Temperature And Humidity Monitoring. *SSRN Electron. J.* 2020; in press.
91. Palazzi, V.; Gelati, F.; Vagliani, U.; Alimenti, F.; Mezzanotte, P.; Roselli, L. Leaf-Compatible Autonomous RFID-Based Wireless Temperature Sensors for Precision Agriculture. In Proceedings of the 2019 IEEE Topical Conference on Wireless Sensors and Sensor Networks, Orlando, FL, USA, 20–23 January 2019.
92. Kerns, S.C.; Lee, J.-L. Automated Aeroponics System Using IoT for Smart Farming. In Proceedings of the 8th International Scientific Forum, Pembroke, NC, USA, 2017., 7–8 September.
93. Sudduth, K.A.; Drummond, S.T.; Kitchen, N.R. Accuracy issues in electromagnetic induction sensing of soil electrical conductivity for precision agriculture. *Comput. Electron. Agric.* **2001**, *31*, 239–264. [[CrossRef](#)]
94. Pongnumkul, S.; Chaovalit, P.; Surasvadi, N. Applications of smartphone-based sensors in agriculture: A systematic review of research. *J. Sens.* **2015**, *2015*, 195308. [[CrossRef](#)]
95. Ariff, M.H.; Ismail, I. Livestock information system using Android Smartphone. In Proceedings of the 2013 IEEE Conference on Systems, Process and Control, Kuala Lumpur, Malaysia, 13–15 December 2013; pp. 154–158.
96. Shafi, U.; Mumtaz, R.; Garcia-Nieto, J.; Hassan, S.A.; Zaidi, S.A.R.; Iqbal, N. Precision agriculture techniques and practices: From considerations to applications. *Sensors* **2019**, *19*, 3796. [[CrossRef](#)] [[PubMed](#)]
97. Benaissa, S.; Tuytens, F.A.M.; Plets, D.; Trogh, J.; Martens, L.; Vandaele, L.; Joseph, W.; Sonck, B. Calving and estrus detection in dairy cattle using a combination of indoor localization and accelerometer sensors. *Comput. Electron. Agric.* **2020**, *168*, 105153. [[CrossRef](#)]
98. Sharma, S.; Raval, J.; Jagyasi, B. Neural network based agriculture activity detection using mobile accelerometer sensors. In Proceedings of the 11th IEEE India Conference: Emerging Trends and Innovation in Technology, Pune, India, 11–13 December 2014.
99. Omran, E.-S.E.; Negm, A.M. *Smart Sensing System for Precision Agriculture*; Springer: Cham, Switzerland, 2020; pp. 77–105.
100. Mahdavian, M.; Wattanapongsakorn, N. Optimizing greenhouse lighting for advanced agriculture based on real time electricity market price. *Math. Probl. Eng.* **2017**, *2017*, 6862038. [[CrossRef](#)]
101. Lork, C.; Cubillas, M.; Ng, B.K.K.; Yuen, C.; Tan, M. Minimizing electricity cost through smart lighting control for indoor plant factories. In Proceedings of the Annual Conference of Industrial Electronics Society, Singapore, 18–21 October 2020.
102. Fu, Q.; Zhang, C.; Xie, J.; Li, Z.; Qu, L.; Cai, X.; Ouyang, H.; Song, Y.; Du, D.; Lin, Y.; et al. Ambient light sensor based colorimetric dipstick reader for rapid monitoring organophosphate pesticides on a smart phone. *Anal. Chim. Acta* **2019**, *1092*, 126–131. [[CrossRef](#)]
103. Kim, C.; Choi, M.; Park, T.; Kim, M.; Seo, K.; Kim, H. Optimization of yield monitoring in harvest using a capacitive proximity sensor. *Eng. Agric. Environ. Food* **2016**, *9*, 151–157. [[CrossRef](#)]
104. Doshi, J.; Patel, T.; Bharti, S.K. Smart Fanning using IoT, a solution for optimally monitoring fanning conditions. In Proceeding of the 3rd International Workshop on Recent Advances on Internet of Things: Technology and Application Approaches (IoT-T&A 2019), Coimbra, Portugal, 4–7 November 2019; pp. 746–751.
105. Lan, L.; Le, X.; Dong, H.; Xie, J.; Ying, Y.; Ping, J. One-step and large-scale fabrication of flexible and wearable humidity sensor based on laser-induced graphene for real-time tracking of plant transpiration at bio-interface. *Biosens. Bioelectron.* **2020**, *165*, 112360. [[CrossRef](#)]
106. Zhang, Y.; Zhang, W.; Li, Q.; Chen, C.; Zhang, Z. Design and fabrication of a novel humidity sensor based on ionic covalent organic framework. *Sens. Actuators B Chem.* **2020**, *324*, 128733. [[CrossRef](#)]
107. Bezzon, V.D.N.; Montanheiro, T.L.A.; De Menezes, B.R.C.; Ribas, R.G.; Righetti, V.A.N.; Rodrigues, K.F.; Thim, G.P. Carbon Nanostructure-based Sensors: A Brief Review on Recent Advances. *Adv. Mater. Sci. Eng.* **2019**, *2019*, 4239073. [[CrossRef](#)]
108. Yuan, C.; Tony, A.; Yin, R.; Wang, K.; Zhang, W. Tactile and thermal sensors built from carbon–polymer nanocomposites—A critical review. *Sensors* **2021**, *21*, 1234. [[CrossRef](#)] [[PubMed](#)]
109. Zhang, W.J.; Van Luttervelt, C.A. Toward a resilient manufacturing system. *CIRP Ann.* **2011**, *60*, 469–472. [[CrossRef](#)]
110. Wang, J.; Dou, R.; Muddada, R.R.; Zhang, W. Management of a holistic supply chain network for proactive resilience: Theory and case study. *Comput. Ind. Eng.* **2018**, *125*, 668–677. [[CrossRef](#)]
111. Mukherjee, A.; Majumdar, S.; Servin, A.D.; Pagano, L.; Dhankher, O.P.; White, J.C. Carbon nanomaterials in agriculture: A critical review. *Front. Plant Sci.* **2016**, *7*, 172. [[CrossRef](#)] [[PubMed](#)]
112. Ndukwu, M.C.; Ikechukwu-Edeh, C.E.; Nwakuba, N.; Okosa, I.; Horsefall, I.T.; Orji, F.N. Nanomaterials application in greenhouse structures, crop processing machinery, packaging materials and agro-biomass conversion. *Mater. Sci. Energy Technol.* **2020**, *3*, 690–699. [[CrossRef](#)]
113. Mishra, P.; Singh, A.; Mishra, R.R.; Ong, S.Y.; Prasad, S.M. Application of Nanotechnology to Enhance the Nutrient Quality of Food Crops and Agricultural Production. In *Nanomaterials in Plants, Algae and Microorganisms*; Elsevier: Amsterdam, The Netherlands, 2018; Volume 1, pp. 453–472.

114. Jiang, J.; Zhang, Q.; Yao, X.; Tian, Y.; Zhu, Y.; Cao, W.; Cheng, T.; Cheng, T. HISTIF: A New Spatiotemporal Image Fusion Method for High-Resolution Monitoring of Crops at the Subfield Level. *IEEE J. Sel. Top. Appl. Earth Obs. Remote Sens.* **2020**, *13*, 4607–4626. [[CrossRef](#)]
115. Faragó, D.; Sass, L.; Valkai, I.; Andrási, N.; Szabados, L. Plantsize offers an affordable, non-destructive method to measure plant size and color In Vitro. *Front. Plant Sci.* **2018**, *9*, 219. [[CrossRef](#)]
116. Rico-Fernández, M.P.; Rios-Cabrera, R.; Castelán, M.; Guerrero-Reyes, H.I.; Juárez-Maldonado, A. A contextualized approach for segmentation of foliage in different crop species. *Comput. Electron. Agric.* **2019**, *156*, 378–386. [[CrossRef](#)]
117. Pérez-Zavala, R.; Torres-Torriti, M.; Cheein, F.A.; Troni, G. A pattern recognition strategy for visual grape bunch detection in vineyards. *Comput. Electron. Agric.* **2018**, *151*, 136–149. [[CrossRef](#)]
118. Fahmi, F.; Trianda, D.; Andayani, U.; Siregar, B. Image processing analysis of geospatial uav orthophotos for palm oil plantation monitoring. In Proceedings of the 2nd International Conference on Computing and Applied Informatics, Medan, Indonesia, 28–30 November 2017; IOP Publishing Ltd.: Bristol, UK, 2018; Volume 978, p. 12064.
119. Sun, Y.; Gao, J.; Wang, K.; Shen, Z.; Chen, L. Utilization of Machine Vision to Monitor the Dynamic Responses of Rice Leaf Morphology and Colour to Nitrogen, Phosphorus, and Potassium Deficiencies. *J. Spectrosc.* **2018**, *2018*, 1469314. [[CrossRef](#)]
120. Zhu, Y.; Cao, Z.; Lu, H.; Li, Y.; Xiao, Y. In-field automatic observation of wheat heading stage using computer vision. *Biosyst. Eng.* **2016**, *143*, 28–41. [[CrossRef](#)]
121. Sadeghi-Tehrani, P.; Sabermanesh, K.; Virlet, N.; Hawkesford, M.J. Automated method to determine two critical growth stages of wheat: Heading and flowering. *Front. Plant Sci.* **2017**, *8*, 252. [[CrossRef](#)] [[PubMed](#)]
122. Maharlooei, M.; Sivarajan, S.; Bajwa, S.G.; Harmon, J.P.; Nowatzki, J. Detection of soybean aphids in a greenhouse using an image processing technique. *Comput. Electron. Agric.* **2017**, *132*, 63–70. [[CrossRef](#)]
123. Liu, H.; Chahl, J.S. A multispectral machine vision system for invertebrate detection on green leaves. *Comput. Electron. Agric.* **2018**, *150*, 279–288. [[CrossRef](#)]
124. Zhong, Y.; Gao, J.; Lei, Q.; Zhou, Y. A vision-based counting and recognition system for flying insects in intelligent agriculture. *Sensors* **2018**, *18*, 1489. [[CrossRef](#)]
125. Li, X.; Ma, Z.; Bienvenido, F.; Feng, Q.; Wang, H.; Alvarez-Bermejo, J. Development of automatic counting system for urediospores of wheat stripe rust based on image processing. *Int. J. Agric. Biol. Eng.* **2017**, *10*, 134–143.
126. McCool, C.; Sa, I.; Dayoub, F.; Lehnert, C.; Perez, T.; Uproft, B. Visual detection of occluded crop: For automated harvesting. In Proceedings of the IEEE International Conference on Robotics and Automation, Stockholm, Sweden, 16–21 May 2016.
127. Davidson, J.R.; Silwal, A.; Hohimer, C.J.; Karkee, M.; Mo, C.; Zhang, Q. Proof-of-concept of a robotic apple harvester. In Proceedings of the IEEE International Conference on Intelligent Robots and Systems, Daejeon, Korea, 9–14 October 2016.
128. Firouzjaei, R.A.; Minaei, S.; Beheshti, B. Sweet lemon mechanical damage detection using image processing technique and UV radiation. *J. Food Meas. Charact.* **2018**, *12*, 1513–1518. [[CrossRef](#)]
129. Tian, F.; Peng, Y.; Wei, W. Nondestructive and rapid detection of potato black heart based on machine vision technology. In Proceedings of the Sensing for Agriculture and Food Quality and Safety VIII, Baltimore, MA, USA, 20–21 April 2016; Volume 9864, p. 98640. [[CrossRef](#)]
130. Wang, Z.; Hu, M.; Zhai, G. Application of deep learning architectures for accurate and rapid detection of internal mechanical damage of blueberry using hyperspectral transmittance data. *Sensors* **2018**, *18*, 1126. [[CrossRef](#)]
131. Wan, P.; Toudeshki, A.; Tan, H.; Ehsani, R. A methodology for fresh tomato maturity detection using computer vision. *Comput. Electron. Agric.* **2018**, *146*, 43–50. [[CrossRef](#)]
132. Maldonado, W.; Barbosa, J.C. Automatic green fruit counting in orange trees using digital images. *Comput. Electron. Agric.* **2016**, *127*, 572–581. [[CrossRef](#)]
133. Niu, Y.; Zhang, L.; Zhang, H.; Han, W.; Peng, X. Estimating Above-Ground Biomass of Maize Using Features Derived from UAV-Based RGB Imagery. *Remote Sens.* **2019**, *11*, 1261. [[CrossRef](#)]
134. Souza, C.H.W.; Lamparelli, R.A.C.; Rocha, J.V.; Magalhães, P.S.G. Mapping skips in sugarcane fields using object-based analysis of unmanned aerial vehicle (UAV) images. *Comput. Electron. Agric.* **2017**, *143*, 49–56. [[CrossRef](#)]
135. Shi, X.; Han, W.; Zhao, T.; Tang, J. Decision Support System for Variable Rate Irrigation Based on UAV Multispectral Remote Sensing. *Sensors* **2019**, *19*, 2880. [[CrossRef](#)]
136. Nhamo, L.; van Dijk, R.; Magidi, J.; Wiberg, D.; Tshikolomo, K. Improving the Accuracy of Remotely Sensed Irrigated Areas Using Post-Classification Enhancement Through UAV Capability. *Remote Sens.* **2018**, *10*, 712. [[CrossRef](#)]
137. Wang, G.; Sun, Y.; Wang, J. Automatic Image-Based Plant Disease Severity Estimation Using Deep Learning. *Comput. Intell. Neurosci.* **2017**, *2017*, 2917536. [[CrossRef](#)] [[PubMed](#)]
138. Sabzi, S.; Abbaspour-Gilandeh, Y.; García-Mateos, G. A fast and accurate expert system for weed identification in potato crops using metaheuristic algorithms. *Comput. Ind.* **2018**, *98*, 80–89. [[CrossRef](#)]
139. Chang, C.-L.; Lin, K.-M. Smart Agricultural Machine with a Computer Vision-Based Weeding and Variable-Rate Irrigation Scheme. *Robotics* **2018**, *7*, 38. [[CrossRef](#)]
140. Yuan, T.; Xu, C.-G.; Ren, Y.-X.; Feng, Q.-C.; Tan, Y.-Z.; Li, W. Detecting the information of cucumber in greenhouse for picking based on NIR image. *Natl. Libr. Med.* **2009**, *29*, 2054.
141. Zhang, Q.; Chen, S.; Yu, T.; Wang, Y. Cherry recognition in natural environment based on the vision of picking robot. *IOP Conf. Ser. Earth Environ. Sci.* **2017**, *61*, 12021. [[CrossRef](#)]

142. Wei, J.; Zhijie, Q.; Bo, X.; Dean, Z. A nighttime image enhancement method based on Retinex and guided filter for object recognition of apple harvesting robot. *Int. J. Adv. Robot. Syst.* **2018**, *15*, 172988141775387. [CrossRef]
143. Shamim Hossain, M.; Al-Hammadi, M.; Muhammad, G. Automatic Fruit Classification Using Deep Learning for Industrial Applications. *IEEE Trans. Ind. Inform.* **2019**, *15*, 1027–1034. [CrossRef]
144. Rueda-Ayala, V.P.; Peña, J.M.; Höglind, M.; Bengochea-Guevara, J.M.; Andújar, D. Comparing UAV-Based Technologies and RGB-D Reconstruction Methods for Plant Height and Biomass Monitoring on Grass Ley. *Sensors* **2019**, *19*, 535. [CrossRef] [PubMed]
145. Han, L.; Yang, G.; Dai, H.; Xu, B.; Yang, H.; Feng, H.; Li, Z.; Yang, X. Modeling maize above-ground biomass based on machine learning approaches using UAV remote-sensing data. *Plant Methods* **2019**, *15*, 10. [CrossRef]
146. Kamilaris, A.; Gao, F.; Prenafeta-Boldu, F.X.; Ali, M.I. Agri-IoT: A semantic framework for Internet of Things-enabled smart farming applications. In Proceedings of the 2016 IEEE 3rd World Forum on Internet of Things, Reston, VA, USA, 12–14 December 2016.
147. Verdouw, C.; Sundmaeker, H.; Tekinerdogan, B.; Conzon, D.; Montanaro, T. Architecture framework of IoT-based food and farm systems: A multiple case study. *Comput. Electron. Agric.* **2019**, *165*, 104939. [CrossRef]
148. Chehri, A.; Chaibi, H.; Saadane, R.; Hakem, N.; Wahbi, M. A Framework of Optimizing the Deployment of IoT for Precision Agriculture Industry. *Procedia Comput. Sci.* **2020**, *176*, 2414–2422. [CrossRef]
149. Elijah, O.; Rahman, T.A.; Orikumhi, I.; Leow, C.Y.; Hindia, M.N. An Overview of Internet of Things (IoT) and Data Analytics in Agriculture: Benefits and Challenges. *IEEE Internet Things J.* **2018**, *5*, 3758–3773. [CrossRef]
150. Glaroudis, D.; Iossifides, A.; Chatzimisios, P. Survey, comparison and research challenges of IoT application protocols for smart farming. *Comput. Netw.* **2020**, *168*, 107037. [CrossRef]
151. Bhowmick, S.; Biswas, B.; Biswas, M.; Dey, A.; Roy, S.; Sarkar, S.K. Application of IoT-Enabled Smart Agriculture in Vertical Farming. In *Lecture Notes in Electrical Engineering*; Springer: Berlin/Heidelberg, Germany, 2019; Volume 537, pp. 521–528.
152. Zhang, X.; Zhang, J.; Li, L.; Zhang, Y.; Yang, G. Monitoring citrus soil moisture and nutrients using an IoT based system. *Sensors* **2017**, *17*, 447. [CrossRef]
153. Agrawal, H.; Dhall, R.; Iyer, K.S.S.; Chetlapalli, V. An improved energy efficient system for IoT enabled precision agriculture. *J. Ambient Intell. Humaniz. Comput.* **2020**, *11*, 2337–2348. [CrossRef]
154. Bauer, J.; Aschenbruck, N. Design and implementation of an agricultural monitoring system for smart farming. In Proceedings of the 2018 IoT Vertical and Topical Summit on Agriculture-Tuscany, Tuscany, Italy, 8–9 May 2018.
155. Saxena, M.; Dutta, S. Improved the efficiency of IoT in agriculture by introduction optimum energy harvesting in WSN. In Proceedings of the 2020 International Conference on Innovative Trends in Information Technology, Kottayam, India, 13–14 February 2020.
156. Ray, P.P. Internet of things for smart agriculture: Technologies, practices and future direction. *J. Ambient Intell. Smart Environ.* **2017**, *9*, 395–420. [CrossRef]
157. Villa-Henriksen, A.; Edwards, G.T.C.; Pesonen, L.A.; Green, O.; Sørensen, C.A.G. Internet of Things in arable farming: Implementation, applications, challenges and potential. *Biosyst. Eng.* **2020**, *191*, 60–84. [CrossRef]
158. Gill, S.S.; Buyya, R.; Chana, I. IoT based agriculture as a cloud and big data service: The beginning of digital India. *J. Organ. End User Comput.* **2017**, *29*, 1–23. [CrossRef]
159. Thakur, D.; Kumar, Y.; Vijendra, S. Smart Irrigation and Intrusions Detection in Agricultural Fields Using I.o.T. *Procedia Comput. Sci.* **2020**, *167*, 154–162. [CrossRef]
160. Mekala, M.S.; Viswanathan, P. CLAY-MIST: IoT-cloud enabled CMM index for smart agriculture monitoring system. *Meas. J. Int. Meas. Confed.* **2019**, *134*, 236–244. [CrossRef]
161. Deebak, B.D.; Al-Turjman, F.; Aloqaily, M.; Alfandi, O. IoT-BSFCAN: A smart context-aware system in IoT-Cloud using mobile-fogging. *Futur. Gener. Comput. Syst.* **2020**, *109*, 368–381. [CrossRef]
162. Farooq, M.S.; Riaz, S.; Abid, A.; Abid, K.; Naeem, M.A. A Survey on the Role of IoT in Agriculture for the Implementation of Smart Farming. *IEEE Access* **2019**, *7*, 156237–156271. [CrossRef]
163. Grieve, B.D.; Duckett, T.; Collison, M.; Boyd, L.; West, J.; Yin, H.; Arvin, F.; Pearson, S. The challenges posed by global broadacre crops in delivering smart agri-robotic solutions: A fundamental rethink is required. *Glob. Food Sec.* **2019**, *23*, 116–124. [CrossRef]
164. Kassim, M.R.M. IoT Applications in Smart Agriculture: Issues and Challenges. In Proceedings of the 2020 IEEE Conference on Open Systems (ICOS), Kota Kinabalu, Malaysia, 17–19 November 2020.
165. Farooq, M.S.; Riaz, S.; Abid, A.; Umer, T.; Zikria, Y. Bin Role of IoT Technology in Agriculture: A Systematic Literature Review. *Electronics* **2020**, *9*, 319. [CrossRef]
166. Pathan, M.; Patel, N.; Yagnik, H.; Shah, M. Artificial cognition for applications in smart agriculture: A comprehensive review. *Artif. Intell. Agric.* **2020**, *4*, 81–95. [CrossRef]
167. Valente, A.; Silva, S.; Duarte, D.; Cabral Pinto, F.; Soares, S. Low-Cost LoRaWAN Node for Agro-Intelligence IoT. *Electronics* **2020**, *9*, 987. [CrossRef]
168. Maksimović, M.; Omanović-Mikličanin, E. Green Internet of Things and Green nanotechnology role in realizing smart and sustainable agriculture. In Proceedings of the VIII International Scientific Agriculture Symposium, Jahorina, Bosnia and Herzegovina, 5–8 October 2017; Volume 2017, pp. 2290–2295.

169. Li, J.; Shen, C. An Energy Conservative Wireless Sensor Networks Approach for Precision Agriculture. *Electronics* **2013**, *2*, 387–399. [CrossRef]
170. López-Morales, J.A.; Martínez, J.A.; Skarmeta, A.F. Improving Energy Efficiency of Irrigation Wells by Using an IoT-Based Platform. *Electronics* **2021**, *10*, 250. [CrossRef]
171. Islam, M.S.; Dey, G.K. Precision agriculture: Renewable energy based smart crop field monitoring and management system using WSN via IoT. In Proceedings of the 2019 International Conference on Sustainable Technologies for Industry 4.0, Dhaka, Bangladesh, 24–25 December 2019.
172. Pisanu, T.; Garau, S.; Ortu, P.; Schirru, L.; Macciò, C. Prototype of a Low-Cost Electronic Platform for Real Time Greenhouse Environment Monitoring: An Agriculture 4.0 Perspective. *Electronics* **2020**, *9*, 726. [CrossRef]
173. Hallett, S.; Hoagland, L.; Toner, E. Urban Agriculture: Environmental, Economic, and Social Perspectives. In *Horticultural Reviews*; John Wiley & Sons: Hoboken, NJ, USA, 2016; Volume 44, pp. 65–120.
174. Trilles, S.; González-Pérez, A.; Huerta, J. A Comprehensive IoT Node Proposal Using Open Hardware. A Smart Farming Use Case to Monitor Vineyards. *Electronics* **2018**, *7*, 419. [CrossRef]
175. Katsoulas, N.; Bartzanas, T.; Kittas, C. Online professional irrigation scheduling system for greenhouse crops. *Acta Hort.* **2017**, *1154*, 221–228. [CrossRef]
176. Duan, Y. Design of intelligent agriculture management information system based on IoT. In Proceedings of the 4th International Conference on Intelligent Computation Technology and Automation, Shenzhen, China, 28–29 March 2011; Volume 1, pp. 1045–1049.
177. Boursianis, A.D.; Papadopoulou, M.S.; Diamantoulakis, P.; Liopa-Tsakalidi, A.; Barouchas, P.; Salahas, G.; Karagiannidis, G.; Wan, S.; Goudos, S.K. Internet of Things (IoT) and Agricultural Unmanned Aerial Vehicles (UAVs) in smart farming: A comprehensive review. *Internet Things*, 2020; 100187, in press.
178. Stočes, M.; Vaněk, J.; Masner, J.; Pavlík, J. Internet of things (IoT) in agriculture—Selected aspects. *Agris Online Pap. Econ. Inform.* **2016**, *8*, 83–88. [CrossRef]
179. Sushanth, G.; Sujatha, S. IOT Based Smart Agriculture System. In Proceedings of the 2018 International Conference on Wireless Communications, Signal Processing and Networking, Chennai, India, 22–24 March 2018.
180. Effendi, M.K.R.; Kassim, M.; Sulaiman, N.A.; Shahbudin, S. IoT Smart Agriculture for Aquaponics and Maintaining Goat Stall System. *Int. J. Integr. Eng.* **2020**, *12*, 8.
181. Tomar, P.; Kaur, G. *Artificial Intelligence and Iot-Based Technologies for Sustainable Farming and Smart Agriculture*; IGI Global: Hershey, PA, USA, 2021.
182. Uddin, M.A.; Mansour, A.; Le Jeune, D.; Aggoune, E.H.M. Agriculture internet of things: AG-IoT. In Proceedings of the 27th International Telecommunication Networks and Applications Conference, Melbourne, VIC, Australia, 22–24 November 2017; Volume 2017, pp. 1–6.
183. Faid, A.; Sadik, M.; Sabir, E. IoT-based Low Cost Architecture for Smart Farming. In Proceedings of the 2020 International Wireless Communications and Mobile Computing, Limassol, Cyprus, 15–19 June 2020; pp. 1296–1302.
184. Jaiganesh, S.; Gunaseelan, K.; Ellappan, V. IOT agriculture to improve food and farming technology. In Proceedings of the 2017 Conference on Emerging Devices and Smart Systems, Mallasamudram, India, 3–4 March 2017; pp. 260–266.
185. Tyagi, S.K.S.; Mukherjee, A.; Pokhrel, S.R.; Hiran, K.K. An Intelligent and Optimal Resource Allocation Approach in Sensor Networks for Smart Agri-IoT. *IEEE Sens. J.* **2020**, *1*, 1. [CrossRef]
186. Nawandar, N.K.; Satpute, V.R. IoT based low cost and intelligent module for smart irrigation system. *Comput. Electron. Agric.* **2019**, *162*, 979–990. [CrossRef]
187. Haris, I.; Fasching, A.; Punzenberger, L.; Grosu, R. CPS/IoT Ecosystem: Indoor Vertical Farming System. In Proceedings of the 2019 IEEE 23rd International Symposium on Consumer Technologies, Ancona, Italy, 19–21 June 2019; pp. 47–52.
188. Belista, F.C.L.; Go, M.P.C.; Lucenara, L.L.; Policarpio, C.J.G.; Tan, X.J.M.; Baldovino, R.G. A smart aeroponic tailored for IoT vertical agriculture using network connected modular environmental chambers. In Proceedings of the 2018 IEEE 10th International Conference on Humanoid, Nanotechnology, Information Technology, Communication and Control, Environment and Management, Baguio City, Philippines, 29 November–2 December 2018.
189. Codeluppi, G.; Cilfone, A.; Davoli, L.; Ferrari, G. LoRaFarM: A LoRaWAN-Based Smart Farming Modular IoT Architecture. *Sensors* **2020**, *20*, 2028. [CrossRef]
190. Tsipis, A.; Papamichail, A.; Koufoudakis, G.; Tsoumanis, G.; Polykalas, S.E.; Oikonomou, K. Latency-Adjustable Cloud/Fog Computing Architecture for Time-Sensitive Environmental Monitoring in Olive Groves. *AgriEngineering* **2020**, *2*, 175–205. [CrossRef]
191. Oliveira, A., Jr.; Resende, C.; Pereira, A.; Madureira, P.; Gonçalves, J.; Moutinho, R.; Soares, F.; Moreira, W. IoT Sensing Platform as a Driver for Digital Farming in Rural Africa. *Sensors* **2020**, *20*, 3511. [CrossRef] [PubMed]
192. Rodríguez-Robles, J.; Martín, A.; Martín, S.; Ruipérez-Valiente, J.A.; Castro, M. Autonomous Sensor Network for Rural Agriculture Environments, Low Cost, and Energy Self-Charge. *Sustainability* **2020**, *12*, 5913. [CrossRef]
193. Mahbub, M. A smart farming concept based on smart embedded electronics, internet of things and wireless sensor network. *Internet Things* **2020**, *9*, 100161. [CrossRef]
194. Smart Farming—Automated and Connected Agriculture. Available online: <https://www.engineering.com/story/smart-farming-automated-and-connected-agriculture> (accessed on 1 May 2021).

195. The Current Technologies That Can Be Used for Smart Agriculture. Available online: <https://ap.fftc.org.tw/article/2457> (accessed on 14 March 2021).
196. Rahimi, M.K.H.; Saad, M.H.M.; Mad Juhari, A.H.; Sulaiman, M.K.A.M.; Hussain, A. A Secure Cloud Enabled Indoor Hydroponic System via ThingsSentral IoT Platform. In Proceedings of the IEEE 8th Conference on Systems, Process and Control, Melaka, Malaysia, 11–12 December 2020; pp. 214–219.
197. Klerkx, L.; Jakku, E.; Labarthe, P. A review of social science on digital agriculture, smart farming and agriculture 4.0: New contributions and a future research agenda. *NJAS Wagening J. Life Sci.* **2019**, *90*, 100315. [[CrossRef](#)]
198. Patil, G.L.; Gawande, P.S.; Bag, V.R. Smart Agriculture System based on IoT and its Social Impact. *Int. J. Comput. Appl.* **2017**, *176*, 1.
199. Specht, K.; Siebert, R.; Hartmann, I.; Freisinger, U.B.; Sawicka, M.; Werner, A.; Thomaier, S.; Henckel, D.; Walk, H.; Dierich, A. Urban agriculture of the future: An overview of sustainability aspects of food production in and on buildings. *Agric. Human Values* **2014**, *31*, 33–51. [[CrossRef](#)]
200. Suh, J. *Sustainable Agriculture in the Republic of Korea*; Springer: Cham, Switzerland, 2018; pp. 193–211.
201. Tong, Z.; Whitlow, T.H.; Landers, A.; Flanner, B. A case study of air quality above an urban roof top vegetable farm. *Environ. Pollut.* **2016**, *208*, 256–260. [[CrossRef](#)]
202. Zhong, C.; Hu, R.; Wang, M.; Xue, W.; He, L. The impact of urbanization on urban agriculture: Evidence from China. *J. Clean. Prod.* **2020**, *276*, 122686. [[CrossRef](#)]
203. Perez, V.M. Study of the Sustainability Issues of Food Production Using Vertical Farm Methods in an Urban Environment within the State of Indiana. Master's Thesis, Universitat Politècnica de Catalunya, Barcelona, Spain, 2014.
204. Artmann, M.; Sartison, K. The Role of Urban Agriculture as a Nature-Based Solution: A Review for Developing a Systemic Assessment Framework. *Sustainability* **2018**, *10*, 1937. [[CrossRef](#)]
205. Nogeire-McRae, T.; Ryan, E.P.; Jablonski, B.B.R.; Carolan, M.; Arathi, H.S.; Brown, C.S.; Saki, H.H.; McKeen, S.; Lapansky, E.; Schipanski, M.E. The Role of Urban Agriculture in a Secure, Healthy, and Sustainable Food System. *Bioscience* **2018**, *68*, 748–759. [[CrossRef](#)]
206. Wolfert, S.; Ge, L.; Verdouw, C.; Bogaardt, M.J. Big Data in Smart Farming—A review. *Agric. Syst.* **2017**, *153*, 69–80. [[CrossRef](#)]

Reproduced with permission of copyright owner. Further reproduction prohibited without permission.